

Uso e manutenzione  
Emploi et entretien  
Gebrauch und Instandhaltung  
Use and maintenance  
Uso y manutención  
Uso e manutenção

# classe 8

**Macchina per caffè**  
**Machine à café**  
**Kaffeemaschinen**  
**Coffee machine**  
**Máquina para café**  
**Máquina para café**

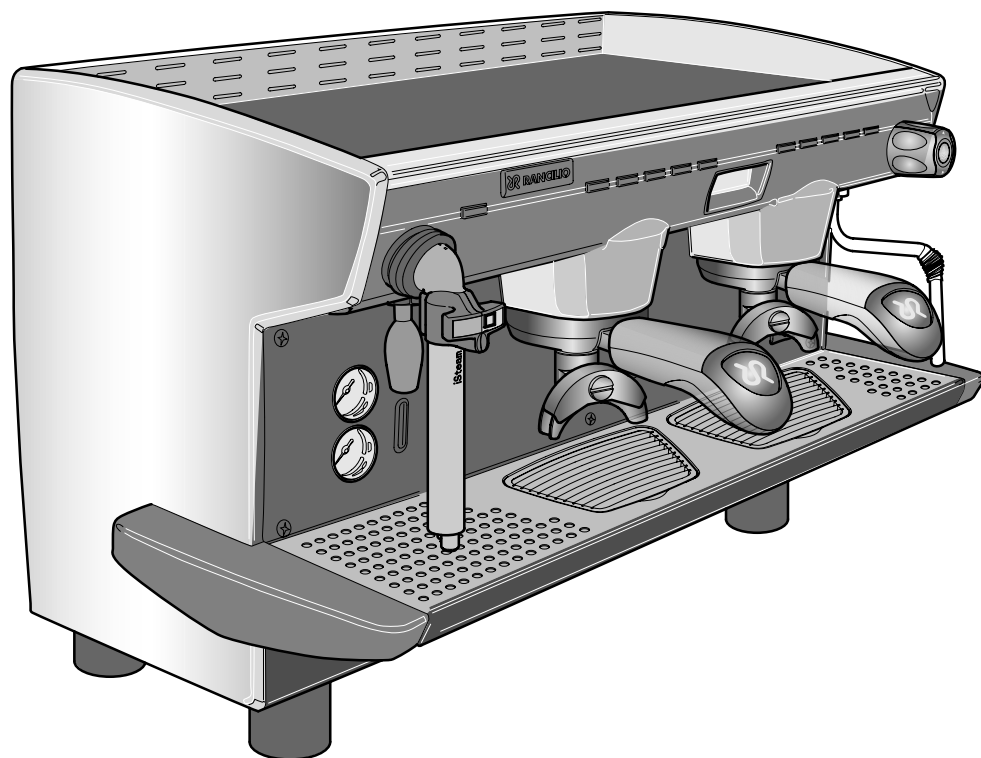

- DE
- S

 **RANCILIO**

*coffeeing the World*

**IT****Gentile cliente,**

*grazie per averci accordato la Sua fiducia.*

*Siamo sicuri che il prodotto che Lei ha acquistato risponderà in pieno alle Sue aspettative, come tutti gli altri articoli della produzione RANCILIO. Il prodotto che Lei si accinge ad usare è il risultato di approfonditi studi e meticolose sperimentazioni fatte dalla RANCILIO per offrirLe quanto di più funzionale, sicuro ed apprezzabile, anche sotto il profilo del design, si possa trovare sul mercato. Il libretto di istruzioni per il corretto uso e manutenzione della macchina La aiuterà a sfruttare al meglio le sue elevatissime possibilità e prestazioni.*

*Con l'augurio di poterLa sempre annoverare tra i nostri clienti, Le auguriamo una buona lettura.*

**FR****Cher Client,**

*Nous Vous remercions pour Votre confiance.*

*Nous sommes certains que le produit que Vous avez acheté correspondra entièrement à Vos désirs, comme du reste tous les articles de la production RANCILIO. Le produit que Vous allez employer est le résultat d'études approfondies et de méticuleux essais effectués par RANCILIO afin de pouvoir Vous offrir le produit le plus fonctionnel, le plus sûr et le plus remarquable, également du point de vue design, que l'on puisse trouver sur le marché. Le petit livre d'instructions pour l'emploi correct et l'entretien de la machine Vous aidera à tirer le maximum de ses grandes possibilités et performances. Nous sommes certains que nos explications sont claires et espérons, cher client, mériter Votre fidélité.*

**DE****Sehr geehrte Kundin/sehr geehrter Kunde,**

*Zuerst möchten wir Ihnen für das uns entgegengebrachte Vertrauen danken.*

*Wir hoffen, dass das von Ihnen gekaufte Produkt Ihren Erwartungen in jeder Hinsicht entsprechen wird-wie übrigens auch all unsere anderen Erzeugnisse. Das Produkt das Sie in Gebrauch nehmen werden, ist das Resultat von sorgfältigen von RANCILIO Untersuchungen und Tests, um Ihnen in Bezug auf Funktionalität, Sicherheit, Leitungsfähigkeit sowie Design ein Produkt anbieten zu können, das das Beste auf Markt befindliche ist. Das Büchlein mit den Anweisungen für eine korrekte Bedienung und Wartung der Maschine wird Ihnen behilflich sein, das Beste aus Ihrem Gerät zu machen. Wir hoffen, dass unsere Erklärungen verständlich sind und dass Sie auch in Zukunft zu unseren Kunden zählen dürfen.*

*Mit freundlichen Grüßen.*

**EN****Dear Customer,**

*First of all, thank you choosing RANCILIO.*

*We are confident that the product you have purchased will come up to all your expectations-just as all our other products are designed to do. The product that you are about to use is the outcome of painstaking research and tests. The Rancilio's consistency assures quite sure that the equipment we have supplied you with, is the most functional, safe and satisfactory of its kind to be found on the market, as regards both its design and its efficiency. The booklet of instructions for its correct use and maintenance will help you to get the best possible service out of your machine. We trust you will find our explanations clear and we may continue, in the future, to count you among our esteemed customers.*

**ES****Muy estimado cliente:**

*muchas gracias por habernos acordado Su confianza.*

*Estamos seguros que el producto que Ud. ha adquirido responderá seguramente a Sus esperanzas, así como es por todos los demás artículos RANCILIO fabrica. El producto que Ud. se apresta a utilizar es el resultado de particulares estudios y pruebas meticolosas hechas por la firma RANCILIO para ofrecerle un producto funcional, seguro y apreciable, también por lo que se refiere al design, seguramente uno de los mejores que Ud. pueda encontrar en comercio. El manual de instrucciones para utilizar correctamente y efectuar la manutención de la máquina, la ayudará a disfrutar a lo máximo las elevadas posibilidades y prestaciones de la misma. Mientras confiamos que Ud. siga siendo siempre Cliente nuestro, le deseamos una provechosa lectura.*

**PT****Prezado Cliente,**

*Obrigado por nos ter dado a sua confiança.*

*Temos certeza que o produto que Você comprou responderá totalmente as suas expectativas, como todos os outros artigos da produção RANCILIO. O produto que Você está para usar é o resultado de estudos profundos e experiências meticolosas feitas pela RANCILIO, para oferece-lhe quanto de mais funcional, seguro e considerável, também sob o perfil do design, que se possa encontrar no mercado. O manual de instruções para o uso correto e manutenção da máquina lhe ajudará a desfrutar ao máximo as suas elevadíssimas possibilidades e desempenhos.*

*Com o desejo de poder tê-lo sempre entre os nossos clientes, desejamo-lhe uma boa leitura.*

# EUROPEAN UNION ONLY

**IT** **Trattamento dei rifiuti delle apparecchiature elettriche ed elettroniche.**  
Smaltire il prodotto seguendo le norme vigenti relative allo smaltimento differenziato presso centri di raccolta dedicati.

Non trattare come semplice rifiuto urbano.

Per qualsiasi informazione necessaria contattare il costruttore all'indirizzo indicato nel libretto istruzioni.

 *Il prodotto risponde ai requisiti richiesti dalle nuove direttive introdotte a tutela dell'ambiente e che deve essere smaltito in modo appropriato al termine del suo ciclo di vita.*

**EN** **Treatment of waste from electric/electronic equipment**  
Dispose of the product in accordance with current regulations concerning differentiated waste disposal in dedicated waste disposal areas.

Do not treat as simple urban waste.

For any information please contact the manufacturer at the address specified in the user manual.

 *The product complies with the requirements of the new directives introduced for the environmental safeguard and must be disposed of appropriately at the end of its life cycle.*

**FR** **Traitement des ordures des équipements électriques et électroniques**  
Écouler le produit conformément aux normes en vigueur concernant l'écoulement différencié auprès de centres de récolte dédiés.

Ne pas traiter comme simples ordures urbaines. Pour toute information nécessaire contacter le constructeur à l'adresse indiquée dans le manuel d'emploi.

 *Le produit est conforme aux caractéristiques requises par les nouvelles directives introduites pour la sauvegarde de l'environnement et doit être écoulé de façon appropriée à la fin de son cycle de vie.*

**DE** **Entsorgung von elektrischen und elektronischen Geräten**  
Das ist Produkt gemäß den geltenden Normen für die Mülltrennung bei den zuständigen Sammelzentren zu entsorgen.

Nicht wie normalen Müll behandeln.

Weitere Informationen sind beim Hersteller unter der in der Gebrauchsanleitung angegebenen Adresse zu erhalten.

 *Das Produkt entspricht den Erfordernissen den neuen Richtlinien über den Umweltschutz, und muss an seinem Lebensende entsprechend entsorgt werden.*

**ES** **Tratamiento de los desechos de los equipos eléctricos y electrónicos**  
Eliminar el producto en los centros de recolección especializados, siguiendo las normas vigentes relativas a la eliminación diferenciada.

No tratar como simple desecho urbano.

Para cualquier información necesaria, contacten al fabricante en la dirección indicada en el manual de instrucciones.

 *El producto responde a los requisitos demandados en las nuevas directivas introducidas para la protección del ambiente y debe ser eliminado de manera apropiada al final de su ciclo de vida.*

**PT** **Tratamento do lixo dos aparelhos elétricos e eletrônicos**  
Jogar o produtos seguindo as normas em vigor relativas à coleta diferenciada em centros de coleta apropriados.

Não tratar como simples lixo urbano.

Para qualquer informação necessária contactar o construtor no endereço indicado no manual de instruções.

 *O produto responde aos requisitos exigidos pelas novas diretrizes introduzidas para tutelar o ambiente e deve ser sucadato em modo apropriado ao final do seu ciclo de vida.*

**NL** **Afvalbehandeling van de elektrische en elektronische apparatuur**  
Verwerk het product volgens de geldende normen m.b.t. de gescheiden afval bij de voorbestemde vuilniscentrums.

Behandel het product niet als eenvoudig stadsvuil.

Neem contact op met de constructeur op het aangegeven adres in deze handleiding voor nadere informatie.

 *Het product beantwoordt aan de door de nieuwe richtlijnen verlangde vereisten ingevoerd ter bescherming van het milieu en moet op passende wijze op het einde van zijn levenscyclus worden verwerkt.*

**DK** **Behandling af affald fra elektrisk/elektronisk udstyr**  
Bortskaf produktet i overensstemmelse med nuværende reguleringer vedr. forskellige affaldsprodukter på deponeringssteder dedikeret til affald.

Må ikke behandles som alm. byaffald.

Kontakt producenten på den specificerede adresse i brugerhåndbogen for yderligere oplysninger.

 *Produktet er i overensstemmelse med de nye direktiver, introduceret for miljøforanstaltningen og skal bortskaffes på behørig vis ved slutningen af dets livscyklus.*

**SE** **Avfallshantering av elektriska och elektroniska apparater**  
Nedskröta produkten genom att följa gällande normer för differentierad sanning på seriösa uppsamlingsställen.

Behandla det inte som vanligt tätortsavfall.

Vid behov av ytterligare information, var vänlig ta kontakt med tillverkaren på den adress som anges i bruksanvisningen.

 *Produkten motsvarar de krav som ställs i de nya miljödirektiven och den måste nedskrötas på ett lämpligt sätt i slutet av sin livscykel.*

**NO** **Behandling av avfall fra elektrisk/elektronisk utstyr**  
Produktet skal avhendes i samsvar med gjeldende forskrifter angående differensiert avfallshandling på dediserte avfallshandlingsområder.

Det må ikke behandles som vanlig byavfall.

For videre opplysninger vennligst kontakt fabrikanten på adressen som er angitt i bruksanvisningen.

 *Produktet etterkommer kravene i de nye miljødirektivene og skal avhendes på en passende måte etter avsluttet bruk.*

**FI** **Sähköisten ja elektronisten laitteiden jätteiden käsittely**

Hävittä tuote noudattaen seuraavia voimassa olevia lajitellun jätteiden käsittelyä koskevia määräyksiä asianmukaiseen jätteidenkäsittelylaitokseen.

Älä käsittele sitä tavallisena kaupunkijätteenä.

Mitä tahansa tietoja varten ota yhteyttä valmistajaan ohjekirjassa olevaan osoitteeseen.

 *Tuote on uusien ympäristöä suojaavien direktiivien vaatimusten mukainen ja se tulee hävittää asianmukaisella tavalla sen käyttöiän päätyttyä.*

**GR** **Επεξεργασία απορριμάτων των ηλεκτρικών/ηλεκτρονικών συσκευών**  
Διαθέστε το προϊόν ακολουθώντας τις ισχύουσες νομοθεσίες περί διαφορετικής επεξεργασίας των απορριμάτων σε ειδικές περιοχές διάθεσης των απορριμάτων. Μη τα διαχειρίζεστε ως απλά αστικά απόβλητα.

Για οποιαδήποτε πληροφορία, επικοινωνήστε με τον κατασκευαστή στη διευθύνση που αναφέρεται στο εγχειρίδιο των οδηγιών.

 *Το προϊόν τηρεί τις προϋποθέσεις που προβλέπουν οι νέες οδηγίες αναφορικά με την προστασία του περιβάλλοντος και πρέπει να διατίθεται με τον κατάλληλο τρόπο μετά το τέλος της χρήσης του.*

**SK** **Zaobchádzanie s odpadmi z elektrických / elektronických zariadení**  
Výrobok likvidujte podľa súčasných predpisov o likvidácii triedeného odpadu na k tomu určených skládkach.

Nezaobchádzajte s ním ako s bežným komunálnym odpadom.

Ak potrebujete akékoľvek informácie, kontaktujte, prosím, výrobcu na adrese uvedenej v návode na použitie.

 *Výrobok zodpovedá požiadavkám nových smerníc zavedených pre ochranu životného prostredia a zlikvidovať sa na konci svojej životnosti musí príslušným spôsobom.*

**HU** **Az elektromos és elektronikai készülékek hulladékkezelése**  
A terméket az erre a célra kijelölt gyűjtőhelyekre adja le követte a szelektív hulladékgyűjtéssel kapcsolatos jelenlegi jogszabályokat.

Ne kezelje közönséges városi hulladékként.

Bármilyen információért forduljon a gyártóhoz, melynek címét a használati útmutatóban találja.

 *A termék megfelel a környezet védelme érdekében újonnan bevezetett irányelvek követelményeinek és ennek megfelelően kell kezelni az élettartamának végeztével.*

**CZ** **Zacházení s odpady z elektrických / elektronických zařízení**  
Výrobek likvidujte podle současných předpisů o likvidaci tříděného odpadu na k tomu určených skládkách.

Nezacházejte s ním jako s běžným obecním odpadem.

Potřebujete-li jakékoli informace, kontaktujte prosím výrobce na adrese uvedené v návodu pro použití.

 *Výrobek odpovídá požadavkům nových směrnic zavedených pro ochranu životního prostředí a zlikvidovat se na konci své životnosti musí příslušným způsobem.*

**ET** **Elektri- ja elektroniseadmete jäätmete töötlemine**  
Tootest lahtisaamist peab läbi viima vastavalt käibivatele eeskirjale, mis käsitlevad jäätmetest eristatud lahtisaamist selleks mõeldud jäätmetest lahtisaamise alades.

Mitte töödelda nagu tavalisi majapidamisjäätmeid.

Mistahes informatsiooni saamiseks pöörduge palun tootja poole aadressil, mis on märgitud kasutaja käsiraamatus.

 *Toode vastab uutele nõuetele, mis on esitletud keskkonna kaitsmiseks ja sellest peab reeglipäraselt lahti saama selle elutsükli lõpus.*

**LT** **Kur išmesti elektros \ elektroninės įrangos atliekas.**  
Šalinkite įrangos atliekas atitinkamai esamų taisyklių, kurios liečia tokios rūšies atliekas apie specialias atliekų kaupimo vietas.

Nemeskite atliekas į paprastus miesto šiukšlių konteinerius. Papildomos informacijos kreipkitės į gamintoją nurodytu vartotojo instrukcijoje adresu .

 *Šis produktas atitinka įvestos ekologiniam saugumui naujos direktyvos reikalavimus ir turi būti sunaikintas pasibaigus jo atitikties terminui.*

**SL** **Obdelava odpadkov električnih in elektronskih naprav**  
Odlaganje izdelkov je potrebno vršiti v skladu z veljavnimi predpisi v zvezi z selektivnim odlaganjem odpadkov v centrih za zbiranje odpadkov ki so temu namenjeni. Ne odlagajte ga kot običajne smeti.

Za kakršnokoli informacijo kontaktirajte proizvajalca na naslovu, ki je naveden v priločniku z navodili.

 *Izdelek odgovarja zahtevam novih smernic, ki so uvedene zaradi zaščite življenske sredine in mora biti odložen na ustrezen način po koncu življenjske dobe.*

**PL** **Postępowanie z odpadami pochodzącymi z urządzeń elektrycznych/elektronicznych**  
Produkt musi zostać poddany utylizacji zgodnie z obowiązującymi przepisami dotyczącymi segregowania odpadów w specjalnie do tego wyznaczonych miejscach. Nie wyrzucać razem ze zwykłymi odpadami miejskimi.

W celu uzyskania jakichkolwiek informacji proszę skontaktować się z producentem pod adresem podanym w instrukcji obsługi dla użytkownika.

 *Ten produkt odpowiada wymogom zawartym w nowych dyrektywach wprowadzonych w celu ochrony środowiska i po zakończeniu cyklu eksploatacji musi zostać zutylizowany we właściwy sposób.*

**LV** **Kā utilizēt elektrisko/elektronisko iekārtu atkritumus**  
Iekārtu atkritumus nepieciešams utilizēt atbilstoši spēkā esošajiem noteikumiem, kuri reglamentē dažādu veidu atkritumu utilizēšanu tikai speciālajās atkritumu konteineros. Nemetiet šos atkritumus parastajos kopējos pilsētas atkritumu.

Lai saņemtu jebkuru informāciju, griezties pie ražotāja, kura adrese uzrādīta ekspluatācijas instrukcijā.

 *Dotais produkts atbilst jaunās direktīvas prasībām, kura attiecās uz ekoloģisko drošību, un tas ir atbilstošā kārtībā utilizējams pēc tā, kad nobeigties tā derīguma termiņš.*





*coffeeing the World*

20010 Villastanza di Parabiago (MI)  
Viale della Repubblica 40

**DICHIARAZIONE DI CONFORMITA' CE - DECLARATION DE CONFORMITE CE  
EG-KONFORMITÄTSERKLÄRUNG - EC DECLARATION OF CONFORMITY  
DECLARACIÓN DE CONFORMIDAD CE - DECLARAÇÃO DE CONFORMIDADE CE**

Noi **RANCILIO** Macchine per caffè S.p.A.

Dichiariamo sotto la nostra responsabilità che il prodotto: **Macchina per caffè per uso professionale**  
Déclarons, sous notre responsabilité, que le produit : **Machine à café d'utilisation professionnel**  
Wir erklären auf unsere Verantwortung, daß das Produkt: **Kaffeemaschine für Beruflichgebrauch**  
Declare under our responsibility that the product: **Espresso coffee makers for commercial use**  
Declaramos bajo nuestra responsabilidad que el producto: **Máquina para café de uso profesional**  
Declaramos sob a nossa responsabilidade que o produto: **Máquina para café para uso profissional**



al quale è riferita questa Dichiarazione, secondo quanto prescritto dalle direttive specifiche:  
à laquelle se réfère cette déclaration, selon les prescriptions des directives spécifiques.  
auf das sich diese Erklärung bezieht, Entsprechend der Vorschriften der spezifischen Richtlinien.  
to which this declaration relates is, according to the provisions of the specific directives:  
al cual se refiere esta Declaración, de acuerdo con lo prescrito por las específicas directivas:  
ao qual se refere esta Declaração, segundo quanto prescrito pelas específicas diretrizes:

**98/37/CE**

*Direttiva macchina - Direttiva machine - Richtlinie Maschine - Makers directive - Direttiva máquina - Diretriz da máquina:*

**73/23/CEE, 93/68/CEE**

*Direttiva Bassa Tensione - Direttiva Basse Tension - Niederspannungsrichtlinie - Low Voltage Directive - Directiva Baja Tensión - Diretriz Baixa Tensão:*

**89/336/CEE, 93/68/CEE, 92/31/CEE**

*Direttiva EMC - Direttiva EMC - Richtlinie EMC - EMC Directive - Directiva EMC - Diretriz EMC*

**97/23/CE**

*Direttiva attrezzatura a pressione (PED)-Directive sur les appareillages sous pression (PED)-Richtlinie für unter Druck stehende Geräte (PED) Pressure device directive (PED) - Directiva equipos de presión (PED) - Diretriz aparelhagem de pressão (PED)*

è conforme alle seguenti norme: - conforme aux normes suivantes :  
In Übereinstimmung mit den folgenden Normen: - it complies with the following norms:  
es conforme a las siguientes normas: - É conforme as seguintes normas:

**EN 60335-1, EN 60335-2-75, EN 55014-1, EN 55014-2, EN 61000-3, EN 61000-4, EN 50366**

*Norme EN armonizzate - Normes EN harmonisées - Harmonisierte EN-Norme - Harmonized EN norms - Normas EN armonizadas - Normes EN Harmonia*

Il presidente - The president  
Sig. Giorgio Rancilio

La presente dichiarazione perde la sua validità se la macchina viene modificata senza la nostra espressa autorizzazione.  
La présente déclaration perd sa validité dès lors que la machine est modifiée sans notre expresse autorisation.  
Die vorliegende Erklärung verliert ihre Gültigkeit, wenn die Maschine ohne unsere ausdrückliche Genehmigung verändert wird.  
The present declaration will become invalid should the machine be modified without our specific authorization.  
La presente declaración pierde su validez si la máquina es modificada sin nuestra expresa autorización.  
A presente declaração perde a validade se a máquina é modificada sem a nossa expressa autorização.



Descrizione attrezzatura a pressione-Description de l'appareillage sous pression-Beschreibung der unter Druck stehenden Geräte-  
 Pressure device description-Descripción de los equipos de presión - Descrição dos equipamentos de pressão

	Pressione - Pression Druck - Pressure Presión - Pressão	Temperatura - Température Temperatur - Temperature Temperatura - Temperatura	Fluido - Fluide Flüssig - Fluid Fluido - Fluido	Capacità It-Capacité It-Fähigkeit It- Capacity It-Potencia It- Potência it				
				1 gr.	2 gr.	3 gr.	4 gr.	
Caldaia - Chaudière Kessel - Boiler Caldera - Caldeira	0,18/1,8 Mpa/bar	131,2 C°	Acqua/Vapore - Eau/Vapeur Wasser/Dampf - Water/Steam Agua/Vapor - Agua/Vapor	5	11	16	22	
				Numero scambiatore-Numéro de l'échangeur Nummer des Austauschers- Exehanger number-Número intercambiador Número Intercambiador				
Scambiatore -Echangeur Austauscher -Exchanger Intercambiador Intercambiador	1.2/12 Mpa/bar	131,2 C°	Acqua - Eau Wasser- Water Agua - Agua	0.35 l	1	2	3	4

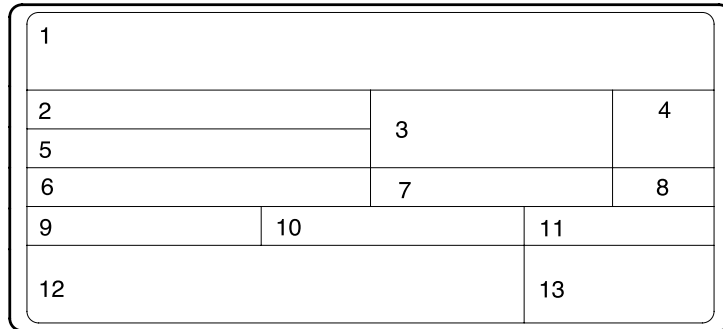

Fig. 1

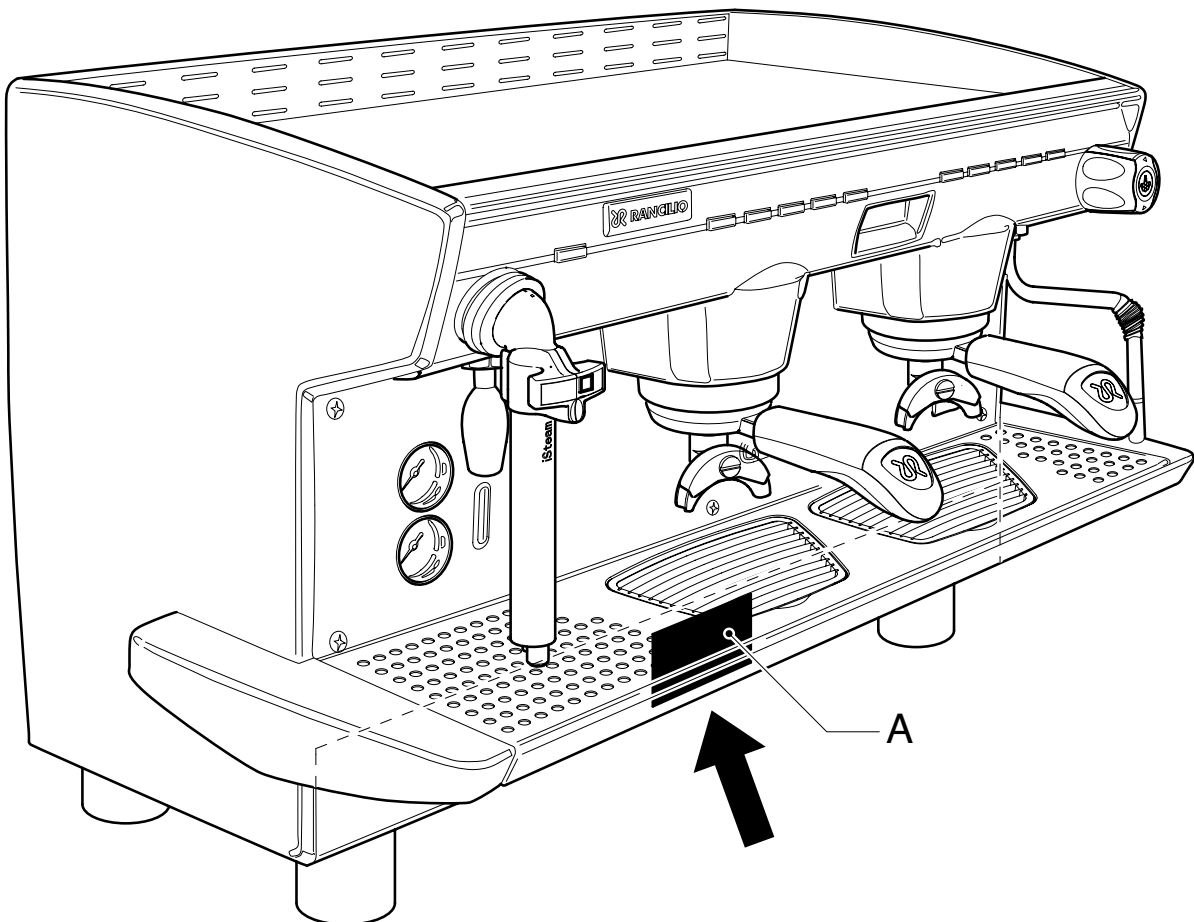
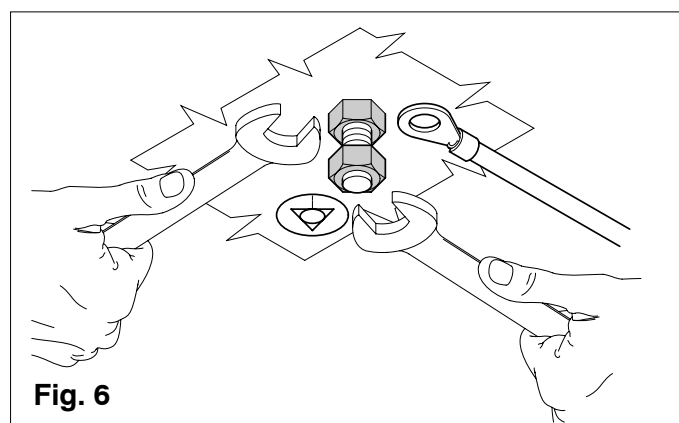
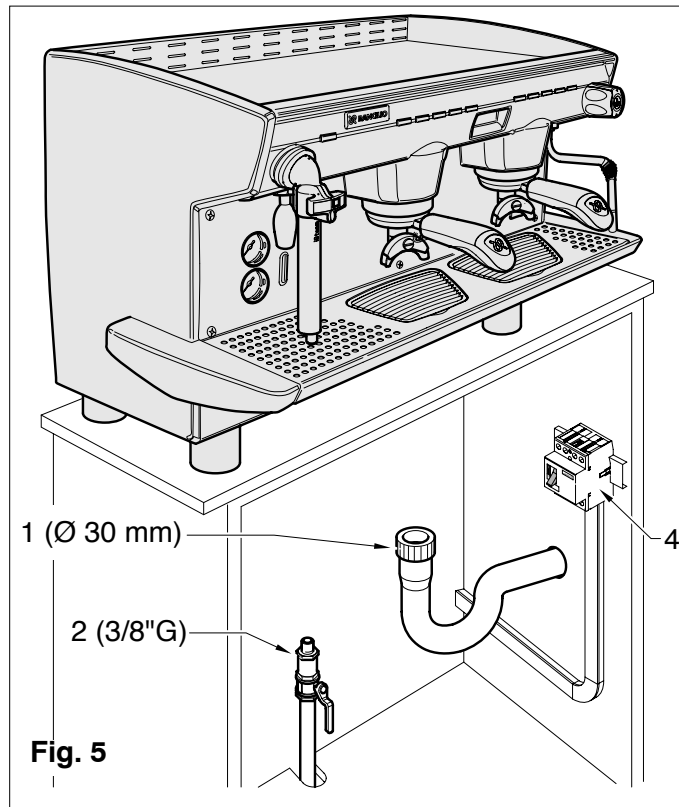
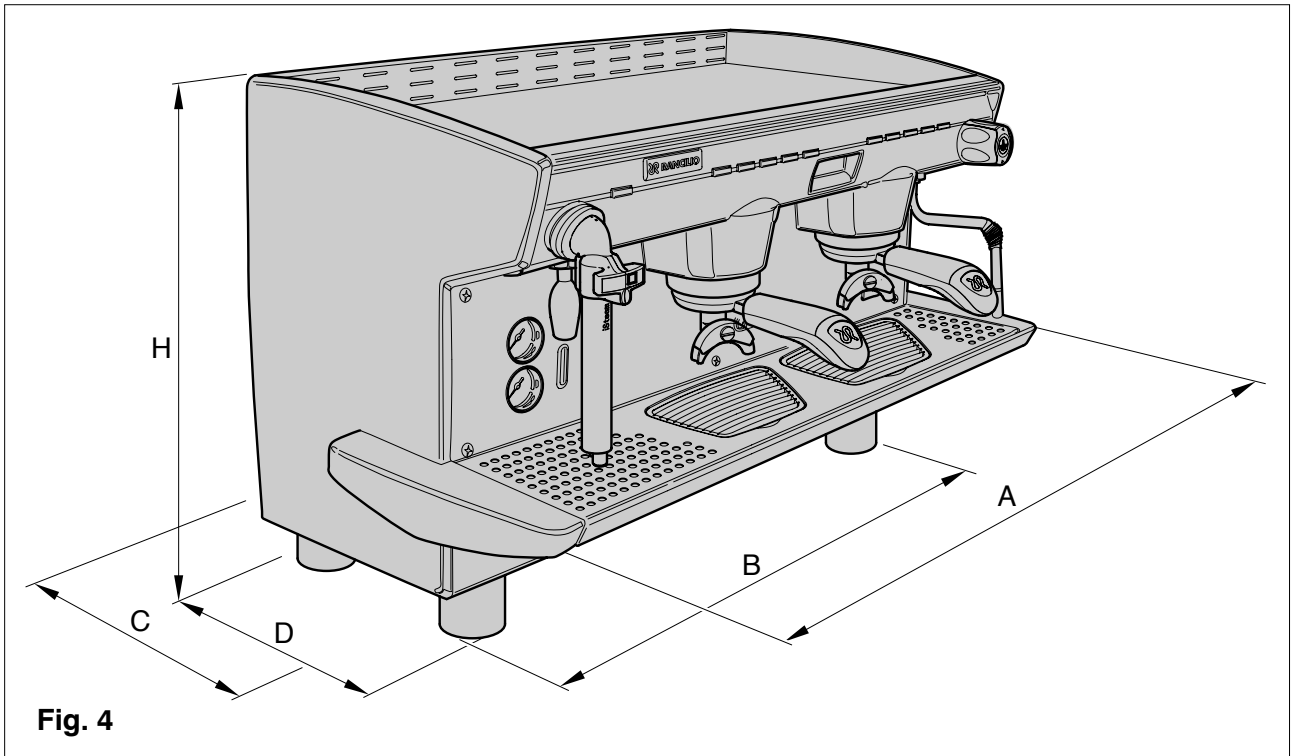

Fig. 2







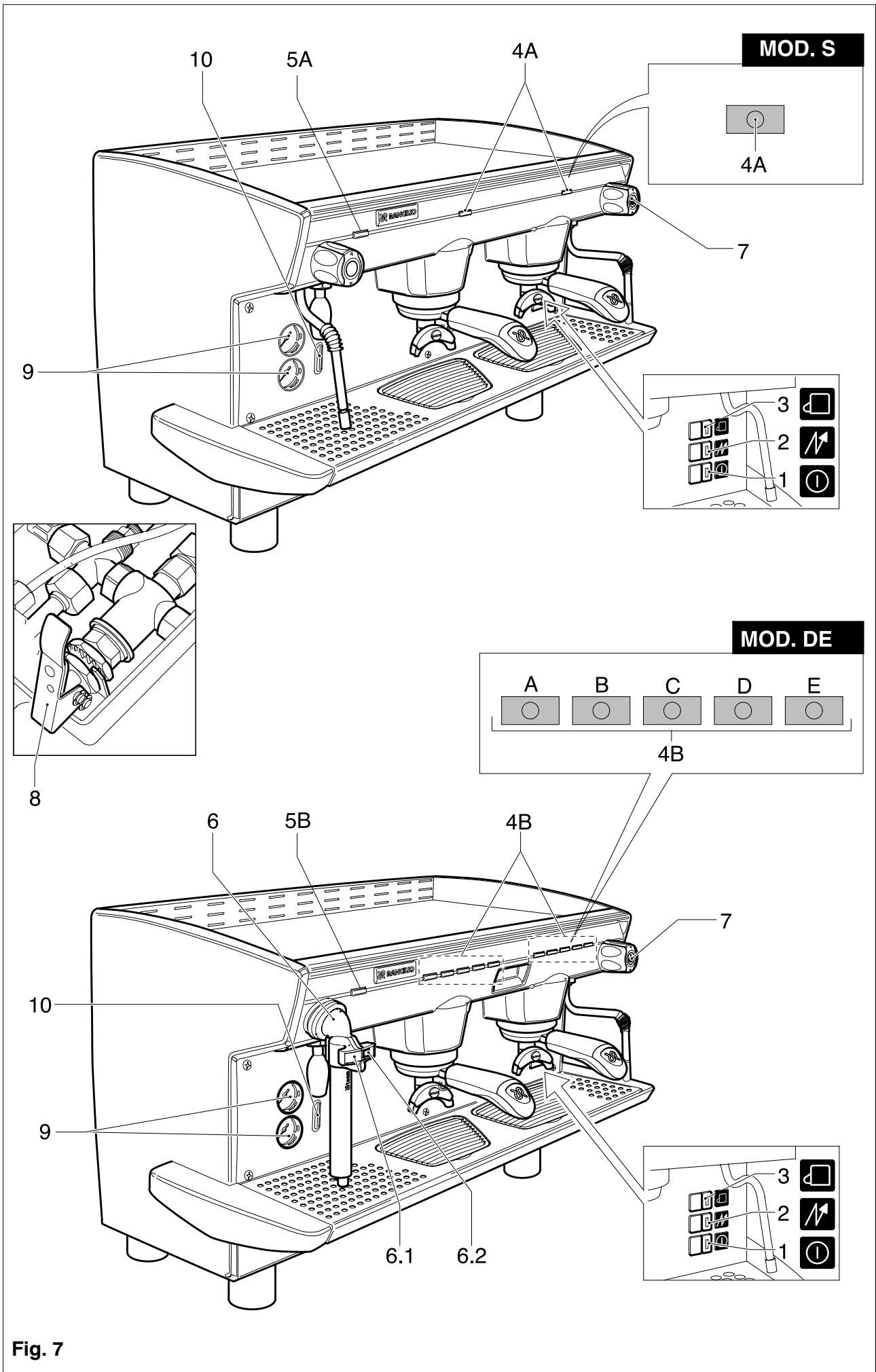
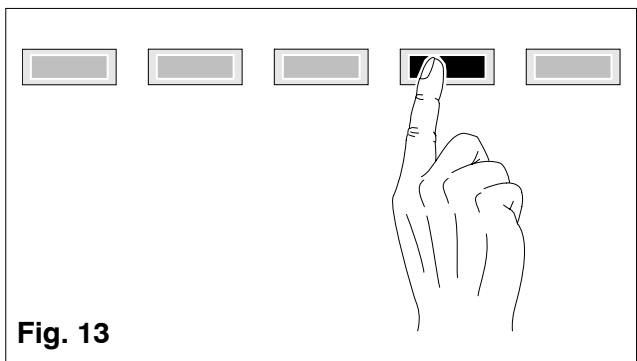
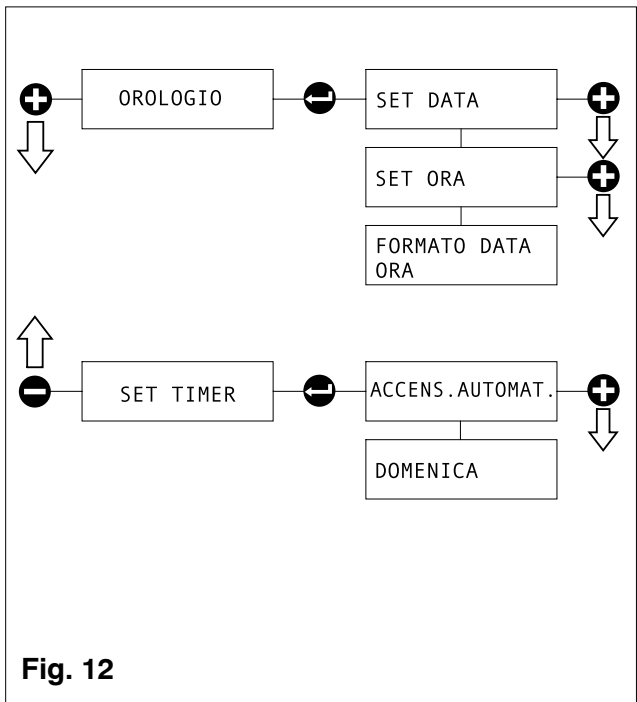
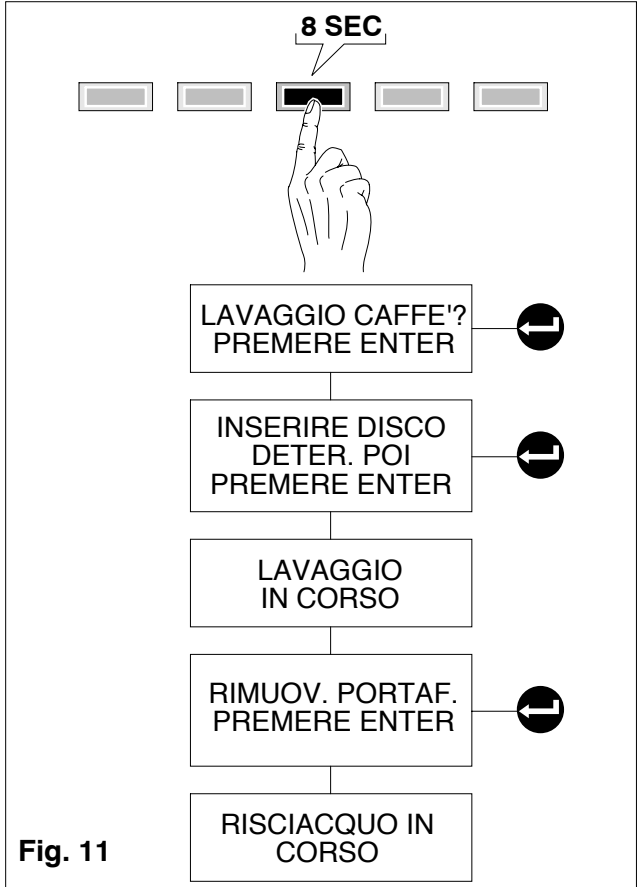
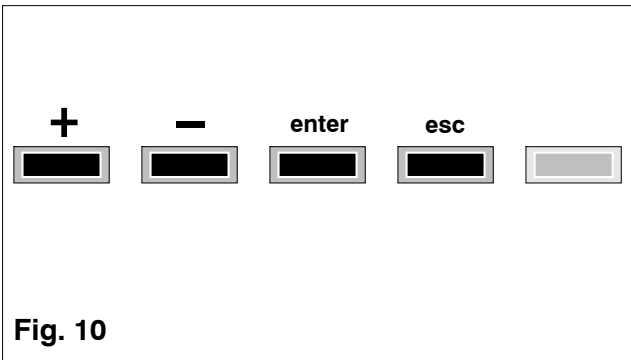
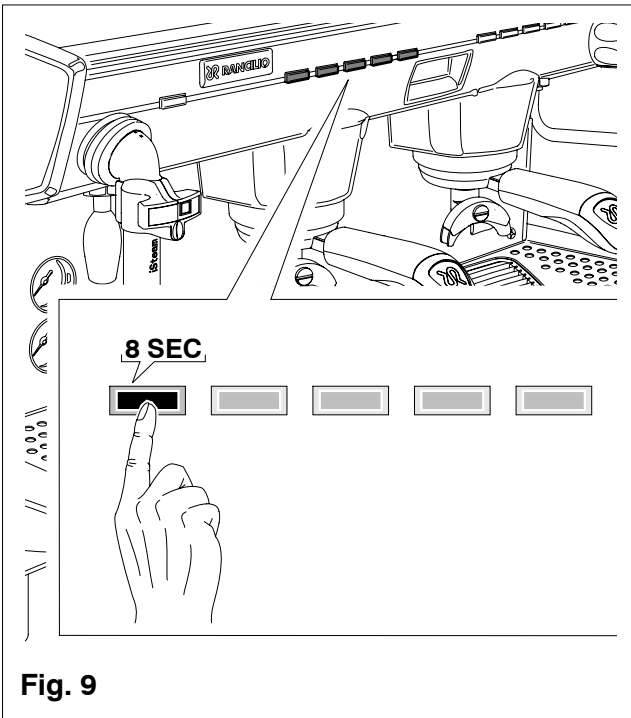
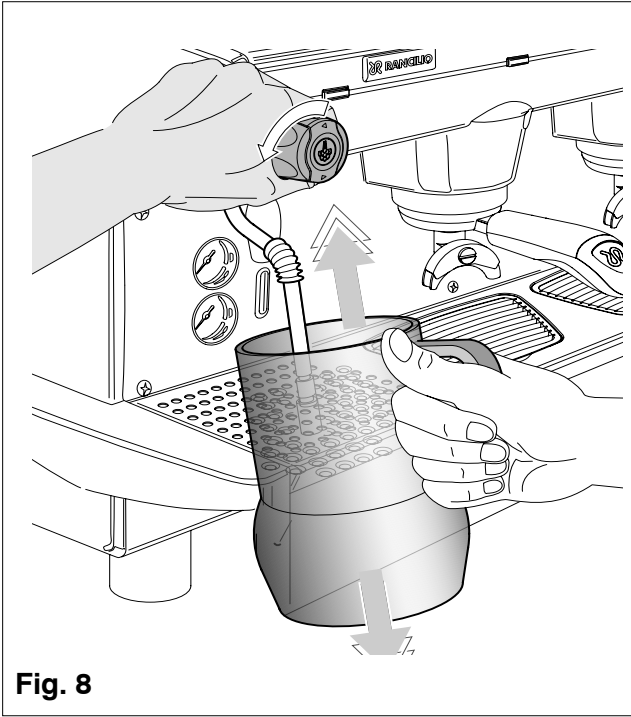
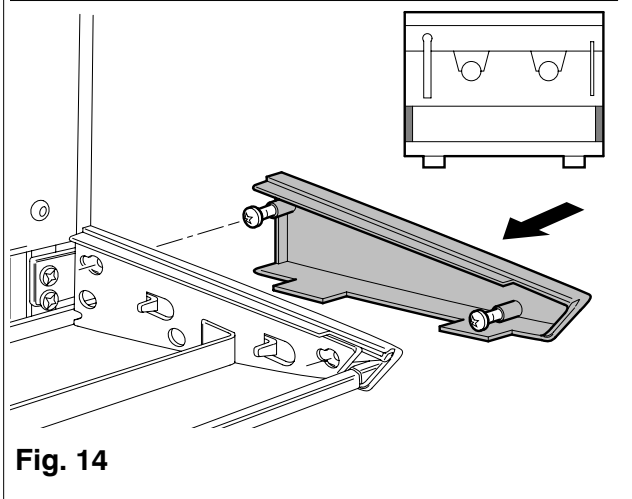
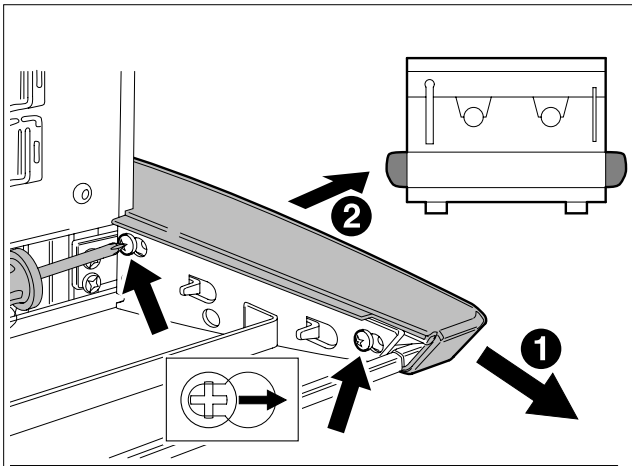
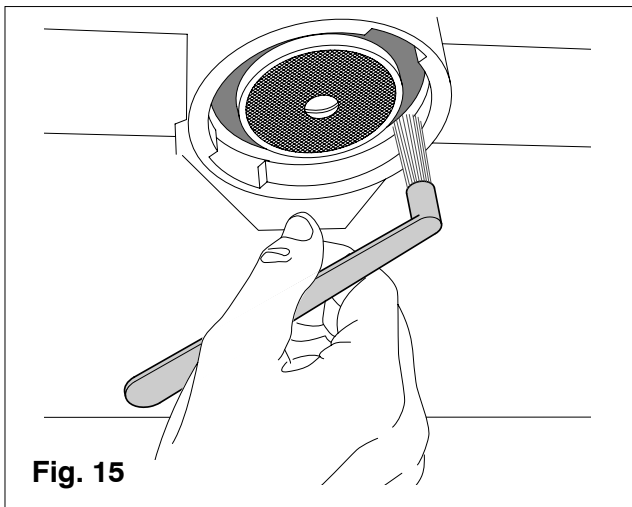

Fig. 7

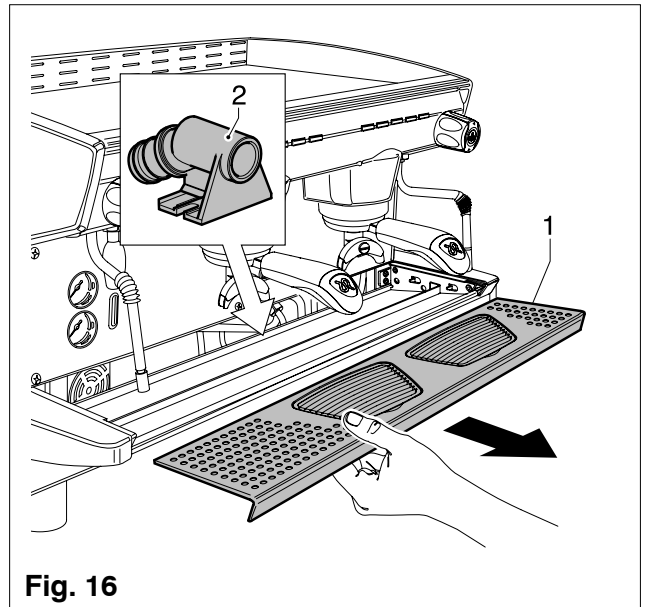



**Fig. 14**



**Fig. 15**



**Fig. 16**

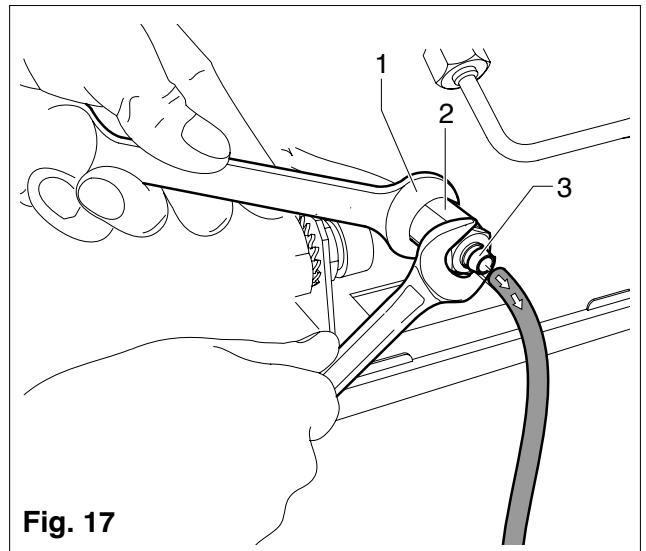

**Fig. 17**

IT	ITALIANO	13-24
FR	FRANCAIS	25-36
DE	DEUTSCH	37-48
<b>EN</b>	<b>ENGLISH</b>	<b>49-60</b>
ES	ESPAÑOL	61-72
PT	PORTUGUÊS	73-84

SCHEMI ELETTRICI SCHEMAS ELECTRIQUES SCHALTPLANE <b>WIRING DIAGRAMS</b> ESQUEMAS ELECTRICOS ESQUEMAS ELÉTRICOS	<b>85-90</b>
---	--------------

SCHEMI IDRAULICI SCHÉMAS HYDRAULIQUES HYDRAULIKPLÄNE <b>HYDRAULIC DIAGRAMS</b> ESQUEMAS HIDRÁULICOS ESQUEMAS HIDRÁULICOS	<b>91-93</b>
---	--------------



*The operations marked with this symbol are to be undertaken exclusively by an installation technician*



*The operations marked with this symbol are to be undertaken by the user.*

## EN ENGLISH

### CONTENTS

Machine identification data .....	50
<b>1. General safety rules.....</b>	<b>50</b>
<b>2. Description .....</b>	<b>51</b>
2.1. Specifications and composition.....	51
2.2. Machine equipment.....	51
2.3. Mechanical protective devices .....	52
2.4. Electric safety devices .....	52
2.5. Aerial noise .....	52
2.6. Vibrations .....	52
<b>3. Technical data.....</b>	<b>52</b>
3.1. Dimensions and weights .....	52
<b>4. Use .....</b>	<b>52</b>
4.1. Precautionary measures .....	53
<b>5. Transport.....</b>	<b>53</b>
5.1. Packaging .....	53
5.2. Inspection on receipt.....	53
<b>6. Installation .....</b>	<b>53</b>
6.1. Connections to be made by the user .....	54
6.1.1. Water supply .....	54
6.1.2. Electric supply.....	54
6.2. Preliminary operations .....	54
6.3. Connections .....	54
<b>7. Operation .....</b>	<b>55</b>
7.1. Controls.....	55
7.2. Control instruments.....	55
7.3. Starting up.....	56
<b>8. Use .....</b>	<b>56</b>
8.1. Preparing coffee.....	56
8.2. Preparing cappuccino .....	56
8.3. Warming a beverage.....	56
8.4. Preparing tea, camomile, etc.....	57
8.5. Machines with ISTEAM automatic system	57
8.5.1. Heating Milk or a Drink (ISTEAM).....	57
8.5.2. Preparing Frothed Milk (ISTEAM).....	57
8.6. Programming functions.....	57
8.6.1. Programming panel (DE) .....	57
8.7. Barman programming (DE).....	57
8.7.1. Clock .....	57
8.7.2. Set timer.....	57
8.7.3. Timer cut-out.....	58
<b>9. Adjustments and settings of the dose.....</b>	<b>58</b>
9.1. For models DE .....	58
9.1.1. Adjusting the dose.....	58
9.1.2. Adjusting the quantity of hot water .....	58
9.2. Tray case assembly .....	58
9.3. List of failures.....	58
<b>10. Maintenance .....</b>	<b>59</b>
10.1. Daily .....	59
10.2. Weekly .....	59
10.2.1. Washing of the coffee groups .....	59
10.2.2. Cleaning ISTEAM .....	60
10.3. Periodical .....	60
10.3.1. Renewal of water .....	60
<b>11. Stopping the machine .....</b>	<b>60</b>
<b>12. Troubleshooting .....</b>	<b>60</b>

NAME: **Coffee machine, CLASSE 8 series**

MODEL: **S - DE**

VERSIONS: **1 - 2 - 3 - 4 GROUPS**

The label illustrated on the EC Declaration of Conformity of this instruction manual corresponds to the identification label placed on the machine Fig. 2. (Pos. A).

Label identification (Fig.1):

- |    |                                  |
|----|----------------------------------|
| 1  | Manufacturer                     |
| 2  | Model and version                |
| 3  | Voltage                          |
| 4  | EC conformity mark (if required) |
| 5  | Serial number                    |
| 6  | Boiler data                      |
| 7  | Machine total absorption         |
| 8  | Protection level                 |
| 9  | Motor power                      |
| 10 | Heating element power            |
| 11 | Frequency                        |
| 12 | Conformity marks                 |
| 13 | Year of manufacture              |

## Symbols



Warning signal. The instructions which refer to this signal must be followed with great care in order to avoid accidents or damage to the machine.

This manual is an integral and essential part of the product and must be delivered to the user. The warnings contained in it must be read carefully, as they supply important indications relating to the safety of installation, use and maintenance. Keep this manual for future reference.

## 1. GENERAL SAFETY RULES

- Don't leave the packing elements (plastic bags, expanded polystyrene, nails, cardboard, etc.) within the reach of children, as these elements are potential sources or danger.
- Check that the data on the machine corresponds to that of the electrical supply network, before connecting the equipment.
- Adaptors, multiple sockets and /or extensions must not be used.
- In doubt, request an accurate control of the plant by qualified personnel. The electric plant must be provided with the following safety devices:
  - efficient earth connection;
  - section of conductors suitable for absorption capacity
  - efficient earth leakage protection circuit breaker.
- Install the machine on a water repellent surface (laminated, steel, ceramic, etc.) away from heat sources (oven, cooking stove, fireplace, etc.) and in conditions in which the temperature may not go below 5°C. KEEP WARM.
- Do not leave the machine exposed to atmospheric agents or place them in damp rooms such as bathrooms.
- Do not obstruct the suction or dispersion grilles and do not cover with cloths, etc.
- Keep the packed machine in a dry place, not exposed to atmospheric agents and in conditions in which the temperature does not go below 5°C. Do not stack more than three items of the same kind. Do not place heavy items on the packaging.
- In an emergency, such as the breaking out of a fire, unusual noise, overheating, etc., take immediate action, disconnecting the power and closing gas and water taps.
- Only use original spare parts in order to avoid compromising the safety and proper functioning of the machine.



*Erroneous installation can cause damage to people, animals and things for which the manufacturer cannot be considered responsible*

## 2. DESCRIPTION

The machines in the CLASSE 8 series have been designed to prepare express coffee and hot beverages.

A positive-displacement pump inside the machine powers the heater in which the water is heated. By pressing the appropriate buttons, water is supplied to the spouts in the form of hot water or steam, according to needs.

The hot water used to make drinks comes from the boiler.

The machine is composed of a steel carrying structure on which the mechanical and electrical components are fitted. These are completely covered with panels made of plastic and steel.

The beverages are dispensed at the front of the machine, where all the buttons, control devices and dispensers are to be found.

There is a cup-warming plate on the top of the machine.

### 2.1. Specifications and composition (Fig.3)

	A	B	C	D	E
DE	-	ok	1 - 2 - 3 - 4	2	1
S	ok	-	1 - 2 - 3 - 4	2	1

#### Legend:

**A** Semiautomatic system; manual dispensing start and stop.

**B** Automatic system; electronic control of coffee and hot water doses dispensed.

**C** N. of coffee dispensing units.

**D** N. of steam spouts.

**E** N. of hot water spouts.

1	Steam tap
2	Steam spout
3	ISTEAM button panel (Mod.DE)
4	ISTEAM steam jet (Mod.DE)
5	Coffee dispensing unit
6	Coffee dispensing button panel (Mod.S - DE)
7	Manual water supply button
8	Level indicator
9	Gauge
10	Power on-off switch and led
11	Switch and boiler resistance engagement light.
12	Hot water key
13	Display (Mod.DE)
14	Programming panel (Mod.DE)
15	Hot water spout
16	Cup heating resistance switch

### 2.2. Machine equipment

	1 GROUP	2 GROUP	3 GROUP	4 GROUP
1 dose filter holde	1	1	1	1
2 dose filter holde	1	2	3	4
Filters	2	3	4	5
1 mt. supply pipe	1	1	1	1
1,5 mt. supply pipe	1	1	1	1
1,5 mt. drainage pipe	1	1	1	1
Pipe connections	1	1	1	1
Blind disks for cleaning	1	2	3	4
Doser and presser	1	1	1	1
Instruction manual	1	1	1	1
Brush	1	1	1	1

## 2.3. Mechanical protective devices

The machine is equipped with the following protective devices:

- complete panelling protection of all the parts subject to heat and of the steam and hot water supplier;
- cup-warmer plate supplied with a tray to collect spill liquids;
- work surface provided with grill and tray to collect spill liquids;
- expansion valve in the hydraulic system and valve on the boiler to avoid overpressure;
- nonreturn valve on the hydraulic system to avoid flowing back to the main supply.

## 2.4. Electric safety devices

The safety devices provided are:

- 12V low tension push buttons on the DE control key panel;
- thermal protection on the pump motor;
- safe resistance thermal;
- Electronic safety devices.

## 2.5. Aerial noise

Noise level in the working place does not usually exceed 70dB(A).

## 2.6. Vibrations

The machine is supplied with rubber vibration damping feet. In normal working conditions, the machine does not produce vibrations harmful to the operator and the environment.

## 3. TECHNICAL DATA

### 3.1. Dimensions and weights (Fig.4)

	1 GROUP	2 GROUP	3 GROUP	4 GROUP
A mm	690	850	1090	1330
A1* mm	570	730	970	1210
B mm	505	665	905	1145
C mm	500	500	500	500
D mm	300	300	300	300
H mm	490	490	490	490
Boiler capacity in liter.	5	11	16	22
Machine weight kg	53	76	94	112
Water inlet	3/8"	3/8"	3/8"	3/8"
Ø mm drainage	14	14	14	14
<b>Packaging</b>				
Volume m <sup>3</sup>	0.27	0.44	0,55	0.67
Dimensions L x P x H mm	660x670x600	910x670x720	1150x670x720	1390x670x720
Gross weight kg	63	76	90	108

\*A1 (reduced overall dimensions with side case assembly)



You'll find all the technical data on electric connection, on the machine identification label Fig. 1.

## 4. USE

The machine have been designed, manufactured and protected to be used to make express coffee and hot beverages (tea, cappuccino, etc.). Any other use is to be considered unsuitable and therefore dangerous.



**The manufacturer cannot be held responsible for any damage caused to people or things due to unsuitable, erroneous or irrational use of the machine.**

The operator must always follow the indications contained in this manual. In the case of a failure or if the machine is not working properly, switch it off and do not attempt any direct repair. Refer exclusively to a service centre.



### The user must not:

- touch the hot surfaces and dispensing areas;
- place liquids containers on the machine;
- put his hands under the spouts during use;
- transport the machine or carry out maintenance operations when the plug is connected or when the machine is hot;
- wash the machine with water or steam jet;
- dip completely or partially the machine in water;
- use the machine if the cable is damaged;
- touch the machine when his hands or feet are wet or damp;
- use the machine when there are children in its proximity;
- allow the machine to be used by children or unfit people;
- obstruct the suction or dispersal grilles with cloth or any other thing;
- do not use the machine when wet or very damp.

### 4.1. Precautionary measures

This machine may only be used with foodstuffs. It cannot be used for heating liquids or grinding any other kind of product that could damage and pollute it.



*The manufacturer cannot be held responsible for damage to people or things caused by unsuitable, erroneous or irrational use.*

## 5. TRANSPORT

### 5.1. Packaging

The machine is delivered in a strong cardboard box with internal protection.

The packaging bears symbols which must be observed during handling and stocking of the item.



*Always keep the package in a vertical position during transport. Do not turn it over or lay it on its side and avoid bumping and exposure to atmospheric agents.*

### 5.2. Inspection on receipt

Check that the machine received corresponds to the one indicated on the delivery note, including any accessories.

Check that it has not been damaged during transport and, if so, inform the forwarder and our customer service office immediately.



*The packing elements (plastic bags, expanded polystyrene, nails, cardboard, etc.) must not be left within reach of children as they are potential sources of danger. Do not dispose of the packing elements in the environment; consign them to firms authorized for their disposal.*



## 6. INSTALLATION

The appliance is only to be installed in locations where use and maintenance is restricted to trained personnel.

The machines are fitted with height adjustable feet.

The support surface shall be levelled, dry, smooth, steady and stable and at such a height that the cup-warming surface is at over 150 cm from ground. Do not use water jets or install where water jets are used.

In order to guarantee normal operation, the machine must be installed in areas that the environmental temperature is between +5°C ÷ +32°C and humidity of not over 70%.

It does not need to be anchored to the surface and it does not require any technical operations to dampen vibrations in order to operate properly.

It is recommended to leave the area around the machine free to facilitate its use and the performance of any maintenance operations.

If the machine is wet or very damp, wait until it is completely dry before installing or using it. It is always necessary to request an accurate control to qualified service people in order to find any possible damage to the electric components.

Reserve an area near the machine for the installation of the coffee grinding and dosage machine (see relevant documentation).

The machine is usually equipped with a water softener, type DP2 or DP4, which must be connected by the user in compliance with the laws in force. Should a different softener be installed, refer to the documentation of the relevant product.

A dreg drawer should be fitted by the installer.



## 6.1. Connections to be made by the user



*Hook-up must be carried out by qualified personnel in full accordance with federal, state and local regulations.*

### 6.1.1. Water supply (Fig.5)



***This equipment is to be installed to comply with the applicable federal, state or local plumbing codes.***

Connections must be installed close to the machine.

- Water drainage pipe 1, having a minimum internal diameter of 30 mm, equipped with a water-trap accessible for inspection.
- Water supply pipe 2, with a 3/8"G cut-off tap.



*Make sure that the maximum supply pressure does not exceed 6.5 bar; otherwise, install a pressure reducer.*



### 6.1.2. Electric supply (Fig.5)

The machine is supplied ready for connection according to the required electrical specifications. Before connecting the machine ensure that the plate details comply with those of the electric distribution network.

The electrical connection cable must be directly connected to the connection provided according to current legislation. Ensure that the earthing system is efficient and in compliance with current legal requirements.

The earthing system and the lightning protection system must be realized in accordance with the provisions of current legislation.

For the supply network use a cable in compliance with standards with protective conductor (earthing wire). For three-phase power use a cable with 3 conductors (3 phases + neutral + earth).

For single phase power supply use a cable with 3 conductors (phase + neutral + earth).

In both cases it is necessary to provide an automatic differential switch 4 (Fig. 5) at the start of the power cable, complete with magnetic release elements in accordance with the identification plate details (Fig. 1). The contacts must have an opening of equal or over 3 mm and with dispersed current protection of 30 mA.

Remember that each machine must be fitted with its own safety elements.

#### **WARNING:**



*Should the power supply cable be damaged it is to be replaced by the manufacturer or by its technical assistance service or by person with equivalent qualification, in order to prevent any risks.*



## 6.2. Preliminary operations (Fig.6)

### POTENTIAL-EQUALIZING CONNECTION

This connection, which is the one called for by several norms, avoids electrical potential differences, building up between any equipment that may be installed in the same room. There is a terminal clip on the under side of the base of the machine to which an external potential-equalizing wire should be connected.

This connection is **ABSOLUTELY NECESSARY** and must be made right after the machine is installed.

Use a wire whose cross-sectional area conforms to the existing norms.



## 6.3. Connections

- Place the machine on the horizontal surface previously prepared.

Before connecting, thoroughly wash the mains water pipes:

- Leave the water supply taps running at full pressure for several minutes.
- Connect to the mains water supply.
- Connect the machine to the socket.

Thoroughly wash all the water pipes of the machine:

- Leave the water supply taps running at full pressure.
- Switch on main switch 1 (Fig.7): wait until the boiler fills up to the level set.
- Switch on boiler resistance switch 2 (Fig.7) to begin heating the water in the boiler.
- Operate each unit in order to allow the water to escape for about one minute; repeat the operation twice.
- Deliver steam from the steam jets for about one minute.
- Deliver hot water for about one minute; repeat the operation twice.
- Switch off switches 1 and 2.
- Empty the water from the boiler: see point 10.3.1.



#### **IMPORTANT**

*Should the machine not deliver water for over 24 hours, wash the internal components before beginning work, repeating the operations as described above.*

## 7. OPERATION

### 7.1. Controls (Fig.7)

#### 1 Main switch

Two-position switch with led.

Turn on the switch (led on) the machine is turned (apart from the boiler) and the pump is turned on to fill the boiler;

#### 2 Boiler resistance switch

Two-position switch with led.

On activating the switch (the led comes on) and power is supplied to the resistance for the boiler water.

#### 3 Cup heating resistance switch

Two-phase switch with luminous led.

By turning on the switch (led on), the cup heating resistance is power supplied.

#### 4A Coffee dispensing switch (Mod.S)

Two-position switch:

With switch ON, coffee is dispensed;

With switch OFF, dispensing of coffee is interrupted.

#### 4B Coffee Dispensing Electronic Panel (Mod. DE)

Five buttons with relative led:

**A** Press the button for a second, led on, release button; a small coffee is dispensed.

The led turns off and dispensing ceases.

**B** Press the button for a second, led on, release the button; two small coffees are dispensed from the same unit.

The led turns off and dispensing ceases.

**C** Press the button for a second, led on, release the button; a big cup of coffee is dispensed.

The led turns off and dispensing ceases.

**D** Press the button for a second, led on, release the button; two big cups of coffee are dispensed from the same unit.

The led turns off and dispensing ceases.

**E** Press the button for a second, led on, release the button; coffee is continuously dispensed.

Press the button for a second, led off, release button; continuous dispensing of coffee ceases.

To interrupt brewing once the operation has been activated with buttons **A-B-C-D**, press the same button again or press **E**.

Each time a coffee is dispensed, the LED of the relative button lights up.

During dose programming, the LED of the 5<sup>th</sup> button flashes rapidly.

If the dose is supplied irregularly or the volumetric counter is malfunctioning, the LED of the pressed button flashes dispensing the dose on a time basis.

#### 5A Hot water button (picking up directly from the boiler) with two positions (Mod.S):

With switch ON, the LED flashes and hot water is dispensed directly from the boiler.

With switch OFF, the LED switches off and dispensing stops.

#### 5B Hot water button (Mod.DE)

When the button is pressed, hot water is dispensed directly from the boiler for the set time or until the button is pressed again.

If you press the button for 2 seconds, dispensing is continuous and only stops when the button is pressed again.

Dispensing is discontinued automatically after 30 seconds.

#### 6 ISTEAM steam jet (Optional)

By pressing key 6.1 or 6.2, the following operations are activated:

##### 6.1 Foamed milk

Press the button to excite the steam and emulsion delivery electromagnetic valves until the programmed temperature and froth level are reached or until the function is switched off.

##### 6.2 Steamed milk

Pressing the key excites the steam distribution electro-valves until the programmed temperature is reached or until the same is pressed again.

#### Safety Devices

Dispensing cannot be carried out if the machine has not reached the operating pressure or temperature at least once, and each time that the boiler pressure drops too much.

#### 7 Steam supply handwheel.

*Tap: turn in an anticlockwise direction to open and clockwise to close.*

#### 8 Supplementary manual water filling tap positioned under the discharge basin.

*Press down to fill the boiler.*

### 7.2. Control instruments (Fig.7)

#### 9 Gauge with mobile needle on a fixed dial with a double scale.

*Visual control of the pump (lower manometer) and of the boiler pressure (upper manometer)*

#### 10 Minimum and maximum water level indicator .

*Visual control of water level in boiler.*



### 7.3. Starting up

- Turn on the water supply tap 2 Fig.5.
- Turn the main switch 1; the pump is activated, filling the boiler.
- When the water reaches the correct level, the pump stops.  
Turn the main switch 2 to begin heating the water in the boiler then turn each one until water begins to flow from them.
- Wait for the machine to reach its working pressure and to reach the correct thermal balance.



## 8. USE

The machine has a top shelf on which the cups are kept and heated, ready for use.

This is very important to obtain good coffee as the pre-warmed cup stops the coffee from growing cold too quickly.

### 8.1. Preparing coffee

- Unclamp the filter-holder from the dispensing unit and knock any grouts out into the drawer especially provided for this purpose, taking care not to damage the rim of the filter.
- Use the filter for 1 or 2 coffees, according to need.
- Fill the filter with the measure of coffee, level it off and press it down gently with the presser.
- Remove any ground coffee that has stuck to the rim of the filter while pressing.



*If ground coffee is left on the rim of the filter, a leaktight seal is not ensured, with consequent leaking of water and coffee grounds.*

- Lock the filter-holder into the dispensing unit firmly to obtain a leaktight seal.
- Place the cups under the spouts and start pouring using control 4 or button panel 5 according to model (Fig.7).
- When the coffee has been poured, leave the filter-holder attached to the dispensing unit until the next coffee is required.



*When pouring, beware of the hot parts of the machine, especially the coffee dispensing units, the steam and hot water spouts. Do not put your hands for any reason under the units and the spouts when they are operating.*

*The grinding of the coffee beans is of fundamental importance to the making of good coffee, and the granular texture of the resulting grounds should be such that it takes 25-30 seconds to produce the beverage. If the coffee is ground too coarsely the coffee will be pale in colour and weak in flavour, with only a very small amount of white cream, and if the grounds are too fine, the coffee will be dark with no cream. Good coffee can only be made if the beans are freshly and uniformly ground (only possible when the blades of the coffee grinder are sharp) and are then measured out into the correct quantities (roughly 6 grams per measure).*

*The importance of freshly ground coffee beans is due to the fact that once ground, they rapidly lose their aromatic qualities, and fats present in the beans go rancid.*

### 8.2. Preparing cappuccino (Fig.8)

- Make cup of cappuccino with the express coffee.
- Use a high and narrow jug, half-filled with milk.
- Place the jug under the spout so that the nozzle touches the bottom.
- Turn on the steam tap and lower the jug so that the nozzle is almost at the surface of the milk.
- Now, raise and lower the vessel constantly so that the steam nozzle is immersed in and out of the milk to create the froth.
- Turn off the steam tap and pour the milk into the cup.



*Immediately after carrying out this operation, clean the spout with a sponge or a clean cloth so that the milk does not dry on it. Be careful as the spout is hot and may burn your hand.*

### 8.3. Heating a beverage

- Immerse the steam spout into the liquid to be heated.
- Gradually turn on the steam tap 7 Fig.7; the steam that bursts in the liquid heats it to the desired temperature.
- Turn off the steam tap when the desired temperature has been reached.



*Immediately after carrying out this operation, clean the spout with a sponge or clean cloth. Be careful as the spout is hot and may burn your hand.*

## 8.4. Preparing tea, camomile, etc.

- Place the jug under the hot water spout and use the delivery control according to the model (Fig.7). When the desired quantity has been obtained, turn off the switch.
- Add the beverage desired.

### Models DE

For these models, hot water is dispensed in specific measures (see paragraph 9, adjusting the dose of hot water).

To dispense hot water in different quantities, proceed as follows:

- Hold down the delivery control 5B Fig.7 for at least four seconds then release the button; the machine continuously delivers water.
- When the desired measure has been obtained, press the button again to interrupt delivery.

*When the dose of hot water is being delivered electronically, delivery can be interrupted by pressing the button 5B.*

*When purified water is used, these beverages often assume a darker colour.*

*Should the user prefer a lighter coloured drink, draw fresh water from an ordinary tap and proceed with the heating phase as described in point 8.3.*

## 8.5. Machines with ISTEAM automatic system (Fig.7) (only Mod. DE)

### 8.5.1 Heating Milk or a Drink (ISTEAM)

- Immerse the wand in the drink
- Press button 6.2 on the keypad (Fig.7)
- The display will show the temperature of the drink
- Press button 6.2 again to stop heating at the desired temperature.
- Wait for the machine to stop automatically at the programmed temperature.

### 8.5.2. Preparing Frothed Milk (ISTEAM)

- Immerse the wand in a container containing at least 250 cc of milk (the sensor must be at least 3 cm below the water level).  
To obtain best results, use refrigerated milk ( $\leq 5^{\circ}\text{C}$ )  
- ( $\leq 41^{\circ}\text{F}$ )
- Press button 6.1 on the keypad (Fig.7)
- The display shows the temperature of the milk.
- Press button 6.1 again to stop the machine at the desired temperature and emulsion level.
- Wait for the machine to stop automatically at the set temperature and level of froth.

## 8.6 Programming functions

### 8.6.1 Programming Panel (Mod.DE)

Use the first coffee keyboard with keys having the following functions (Fig.10):

- |                   |  |
|-------------------|--|
| 1° Button “+”     | To move to a higher level in the programming menus. Or to increase the value |
| 2° Button “-”     | To move to a lower level in the programming menus. Or to decrease the value  |
| 3° Button “enter” | To enter the programming menu. Or to confirm entries                         |
| 4° Button “esc”   | To quit the menu<br>Or to quit programming mode.                             |
| 5° Button         | Key off.   |

### 8.7 Barman Programming (Mod.DE) (Fig.12)

By keeping key 1 of keyboard 1 pressed for 8 seconds you will enter programming.

By pressing “+” and “-” keys the following sub-menus will be browsed:

Programming with the following sub-menus:

- Clock
  - Set date
  - Set time
  - Date/time format
- Set timer
  - Stand by timer
  - Sunday

#### 8.7.1.Clock

Sub-menu to set date and time and mode (24 hours or English 12 hours and date with dd/mm/yy or mm/dd/yy)

#### 8.7.2 Set timer

Menu to set automatic switching on/off of the machine as follows:

- select automatic or manual switching on (to enable function or not)
- set switching on time for every day of the week
- set working hours

To browse from one menu to another press “+” or “-”, to enter a sub-menu or to confirm a variation press “enter”, to exit press “esc”.

The value that can be modified with “+” or “-” keys is flashing.

### 8.7.3 Timer-cut-out (Fig.13)

If the machine is turned off by the program, by pressing key 4 of keyboard 1 at least for 3-4 seconds it will turn on again and remain on until the following programmed stop or by pressing the same key again. If the machine is switched on by the programme, by pressing key 4 of the first push-button panel for at least 3-4 seconds it will switch off and remain off until switch-on is programmed again or the same key is pressed again.

## 9. ADJUSTMENT AND SETTING OF THE DOSE

### 9.1. Models DE

It is possible to adjust the dose of coffee and hot water dispensed by electronically controlled models. (If the function is enabled)

#### 9.1.1. Adjusting the dose

The quantity of coffee and hot water dispensed can be adjusted using the button panel or the hot water controls.

- 1 Press the button **E** on any button panel and hold it down for 8-10 seconds until water stops flowing from the dispensing unit and the led of the continuous button on the first button panel on the left begins flashing.
- 2 It is necessary to act as to make 1 or 2 cups in order to reach the correct coffee amount adjustment in the cup.
- 3 Put the filter-holder (with ground coffee) on the left unit and the cup under the spout.
- 4 Operate the selected button (i.e. button **A** for one small cup).
- 5 Once the required coffee amount in the cup has been reached, press the stop button **A**. Coffee will stop pouring and the microprocessor will store the dose.
- 6 Press the continuous button **E** again; the led will go out and the machine will store the new quantity.
- 7 Make the coffee and check the cup amount in order to check that programming is correct.

If some doses have to be changed (**A-B-C-D**), once at point 5 repeat the instructions in points 3-4-5 for each dose, remembering to use the filter-holder with relevant filter and freshly ground coffee. Then carry out point 6 and repeat point 7 to check all changed doses.

If all units are to be programmed with the same doses, the selection of coffee doses is finished. If the dosage of another unit is to be changed (1-2-3-4 doses), proceed as indicated in the above-mentioned point 1-7, using only the button panel of the selected unit.

### 9.1.2. Adjusting the quantity of hot water

Proceed as follows:

- 1 Press the continuous **E** button on any button panel and hold down for 8-10 seconds until water stops flowing from the dispensing unit and the led of the **E** button on the first button panel on the left starts flashing. The machine is ready to accept quantity variations.
- 2 Put a cup or a jug to receive the water under the water spout 15 (Fig.3).
- 3 Push the delivery button 5B (Fig.7)
- 4 Once the required amount is reached, press the button 5b again. Water will stop pouring and the microprocessor will store the dose.
- 5 Once adjusted, press the stop-continuous button **E** on any button panel; the led will go out and the machine will store the new quantity.
- 6 Pour out doses of hot water to check that programming is correct.

#### WARNING!

The amount of hot water dispensed can be controlled by proceeding as follows:

- press the hot water control button 5B and hold down for at least 2 seconds; when the button is released, the machine will dispense water continuously.;
- to manually stop dispensing, press the water control button 5B again when the required amount has been dispensed.

To stop dispensing the measured amounts of hot water, press the water control button 5B.

### 9.2. Tray case assembly (Optional) (Fig.14)

The machine is provided with two lateral housing to be applied to the tray group if the available space does not allow, during installation, to install the machine in standard version.

To replace the cases installed on the machine, loosen the 3 screws (Fig.21), take off and remove the right case and replace with the one having smaller dimensions.

### 9.3. List of failures

- |            |  |
|------------|--|
| <b>E00</b> | CPU diagnosis                              |
| <b>E01</b> | Water lacking                              |
| <b>E02</b> | Pressure lacking                           |
| <b>E03</b> | Boiler temperature sensor in short circuit |
| <b>E04</b> | Boiler temperature sensor cut off          |
| <b>E05</b> | Level board lacking                        |
| <b>E06</b> | IDS connection lacking                     |



## 10. MAINTENANCE

*Maintenance operations have to be carried out when the machine is off and cold and the plug is disconnected. Some particular operations have to be effected when the machine is operating.*



*Do not clean the machine by using metal or abrasive devices, such as steel wool, metal brushes, needles, etc. or general detergents (alcohol, solvents, etc.)*

*When necessary, use special detergents for coffee machines that can be bought in specialized service centres.*

### 10.1. Daily (Fig.15)

Use a clean cloth or sponge that does not leave hairs or fluff (preferably cotton or linen).

- Carefully clean the outside surface, following the grain of the satin finish on the parts in stainless steel.
- Clean the steam and hot water spouts and check that the nozzles are not encrusted (if they become encrusted, be careful not to deform or damage them).
- Clean the spray units and the seals under the casing of the delivery units using the special brush supplied.
- Remove the filter-holders and remove the filter and the clamp which secures the filter, use a brush to remove any coffee deposits and rinse with hot water in order to dissolve any grease deposits.

### 10.2. Weekly



*Operations to be carried out with the machine operative and under pressure.*

- Place the supplied blind filter in the filter-holder, put in a spoonful of detergent in powder for coffee machines and fit the filter-holder in the unit to be cleaned.
- Press the coffee dispensing button and draw water for approx. 30 seconds.
- Stop and start dispensing several times until clean water comes out of the discharge unit tube.
- Remove the filter-holder, take out the blind filter and insert a normal one. Replace the filter-holder on the unit and rinse by drawing water several times.
- Make a coffee to eliminate any unpleasant taste.

#### Cleaning the filters and delivery heads (Fig.16)

Operation to be carried out when the machine is off and cold.

- Prepare a solution of 4 sachets of detergent powder Code **69000124** dissolved in a litre of boiling water in a stainless steel, plastic or glass recipient (**NOT ALUMINIUM OR IRON**).
- Remove the filters and immerse them with the filter holders in the prepared solution, leaving them for at least 10/20 minutes (all night is better).

- Remove them from the container and rinse them thoroughly in running water.
- Remove the cup rack 1 (Fig.16), slide out the drip tray and clean them both.
- Check and clean the drainage sump 4 (Fig.16), removing any sludge with the help of a spoon.
- Remove the cup-holder grid 1 (Fig. 16) and clean discharge 2

### 10.2.1 Washing of the coffee groups

At the fixed time, if the automatic washing mode is enabled, a message on the display requests to wash the coffee groups.

Keep **"ENTER"** button pressed to start washing until the display shows:

**"Group Cleaning?"**

**"press <ENTER>"**

If you press **"enter"** within 10 seconds, the following cycle starts (if you do not leave this menu automatically):

- The display shows:

**"Insert blind**

**then <ENTER>"**

- When you press **"enter"**, the cleaning cycle starts and the display shows:

**"Cleaning runnign"**

The machine carries out n. 10 cycles as follows:

- Starts dispensing from the groups for 10 sec.
- Pauses for 10 sec.

At the end of the 10 cycles, the display reads:

**"Remove filterh.**

**press <ENTER>"**

If you press **"enter"** the display shows:

**"Rinsing"**

The machine carries out n. 2 cycles as follows:

- Starts dispensing from the groups for 30 sec.
- Pauses for 30 sec.

Keeping **"esc"** pressed for 2 seconds, during the cycle the current washing phase will stop and the next phase will take place.

It is advisable to always complete the rinsing cycle to remove any detergent residues.

**N.B.** *In the washing and rinsing phases the groups are operated alternatively.*

In any case the washing of the coffee groups can be enabled whenever necessary according to the previously described procedure.

### 10.2.2. Cleaning ISTEAM

- Clean the ISTEAM nozzle frequently with a sponge or damp cloth. Make sure to clean the lower parts.

### 10.3. Periodical maintenance

Have been fitted with economizers which do not draw water from the boiler to make hot water, the water in the boiler need only to be renewed from time to time.

#### 10.3.1. Renewal of water in the boiler (Fig.17)

To be carried out only by qualified personnel.

- Turn off the machine and wait for the pressure in the boiler to diminish (gauge needle on "0").
- Insert a rubber hose into the hose-end fitting (3) (Fig.17)



- Use the wrench (1) to immobilize the fitting (2) and loosen the hose-end fitting (3).
- Allow the water to flow out completely; then, close the fitting (3) and remove the rubber hose.
- Refill the boiler (paragraph 7.3.).

## 11. STOPPING THE MACHINE

### A - Temporary stop

- Carry out cleaning and maintenance operations.
- Wind up the cable and fasten it to the machine with sticky tape.
- Cover the machine and place it in a dry room. Do not leave it exposed to atmospheric agents and do not allow it to be touched by children or uninitiated persons.

To disconnect from the main power supply, consult qualified personnel.

### B - Definitive stop

- Besides carrying out the operations necessary for a temporary stop, cut off the cable, pack the machine in cardboard, polystyrene or other packing material and consign it to firms authorized for its disposal or to second-hand goods dealers.

## 12. PROBLEMS AND REMEDIES



*Check operations to be carried out by the user with the plug disconnected.*

*For any type of problem or inconvenience not specifically indicated, disconnect the plug and contact our service centre without attempting any direct repairs.*

A) The machine does not start:

- *check that the plug is connected;*
- *In case of power failure wait for the power to return and check if the earth leakage protection circuit breaker or the main switch is on;*
- *check the condition of the plug and the supply cable; if damaged have them replaced by qualified personnel.*

B) There is water under the machine:

- *check that the drainage tray is not obstructed.*

C) Slow dispensing:

- *check that the filters and delivery heads are clean;*
- *check that the coffee is not too finely ground.*

D) Irregular steam delivery:

- *check that the nozzles are not obstructed.*



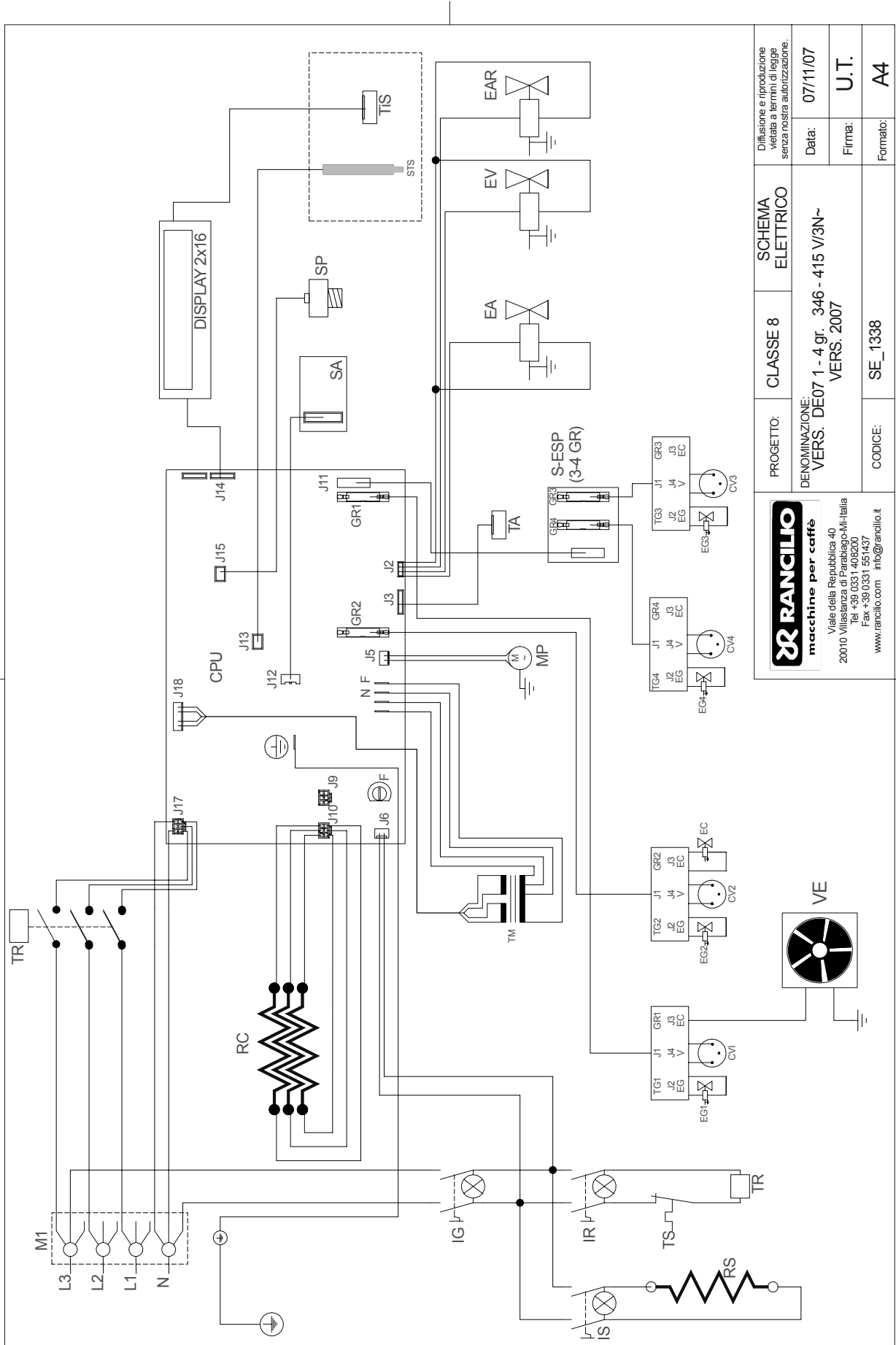

**SCHEMI ELETTRICI  
SCHEMAS ELECTRIQUES  
SCHALTPLANE  
WIRING DIAGRAMS  
ESQUEMAS ELECTRICOS  
ESQUEMA ELÉTRICO**

IT	FR	DE	EN	ES	PT
<b>CA</b> = Centralina autolivello	<i>Contrôle de niveau de l'eau</i>	Wasserniveauekont rolle	<i>Water level control</i>	Transd. autonivel	<i>Central auto nível</i>
<b>CPU</b> = Scheda CPU	<i>Fiche CPU</i>	Karte CPU	<i>CPU Board</i>	Tarjeta CPU	<i>Placa CPU</i>
<b>CV</b> = Contatore volumetrico	<i>Compteur volumétrique</i>	Volumenzaehler	<i>Flow Meter</i>	Contador volum.	<i>Contador volumétrico</i>
<b>EA</b> = Elettrovalvola acqua	<i>Electrovanne eau</i>	Wasserelektroventil	<i>Water electrovalve</i>	Electrovalvula agua	<i>Válvula Eléctrica da água</i>
<b>EAR</b> = Elettrovalvola aria	<i>Electrovanne air</i>	Luftelektroventil	<i>Air electrovalve</i>	Electrovalvula aire	<i>Válvula Eléctrica do ar</i>
<b>EC</b> = Elettrovalvola carico	<i>Electr. de chargement</i>	Speisungselektroventil	<i>Feeding electrovalve</i>	Electrovalv. carga	<i>Válvula Eléctrica abast.</i>
<b>EE</b> = Elettr. Economizzatore	<i>Electr. economiseur</i>	Ekonomiserelektroventil	<i>Economizer electr.</i>	Electr. Economizador	<i>V.Eletr. Economizador</i>
<b>EG</b> = Elettrovalvola gruppo	<i>Electr. du groupe</i>	Gruppenelektroventil	<i>Group Electrovalve</i>	Electrovalvula grupo	<i>Válvula Eléctrica grupo</i>
<b>EV</b> = Elettrovalvola vapore	<i>Electrovanne vapeur</i>	Dampftelektroventil	<i>Steam valve</i>	Electrovalvula vapor	<i>Válvula Eléctrica vapor</i>
<b>F</b> = Fusibile	<i>Fusible</i>	Sicherung	<i>Fuse</i>	Fusible	<i>Fusível</i>
<b>IG</b> = Interruttore generale	<i>Interrupteur general</i>	Hauptschalter	<i>Main switch</i>	Interruptor general	<i>Interruptor geral</i>
<b>IG1-4</b> = Interruttori gruppo	<i>Interrupteurs groupe</i>	Gruppenschalter	<i>Group switches</i>	Interruptores grupo	<i>Interruptores do grupo</i>
<b>IA</b> = Interruttori acqua	<i>Interrupteurs eau</i>	Wasserschalter	<i>Water switches</i>	Interruptores agua	<i>Interruptores da água</i>
<b>IR</b> = Interruttore Resistenza	<i>Interrupteur resistance</i>	Heizungsschalter	<i>Resistance Switch</i>	Interruptor resist.	<i>Interruptor da Resist.</i>
<b>IS</b> = Interruttore scaldatazze	<i>Interrupteur chauffe tasses</i>	Schalter Tassenwärmer	<i>Cup heating switch</i>	Interruptor caliente tazas	<i>Interruptor aquec. xícaras</i>
<b>LC</b> = Lampada livello	<i>Lampe niveau</i>	Lampe für Wasserstand	<i>Level lamp</i>	Lámpara de nivel	<i>Lâmpada nível</i>
<b>M</b> = Morsettiera allacciam.	<i>Boit a bornes pour branchement</i>	Anschlussklemmleiste	<i>Mains Power Connection</i>	Bloque de terminales	<i>Conj. bornes ligação</i>
<b>MP</b> = Motore pompa	<i>Moteur pompe</i>	Pumpen motor	<i>Motor Pump</i>	Motor bomba	<i>Motor da bomba</i>
<b>MRE</b> = Micro Relé pompa	<i>Micro Relé pompe</i>	Micro Relé pumpen	<i>Pump micro Contactor</i>	Micro Relé bomba	<i>Micro Relé bomba</i>
<b>MT</b> = Morsetto di terra	<i>Borne du sol</i>	Erdklammer	<i>Earth connection</i>	Conexion de tierra	<i>Borne do terra</i>
<b>P</b> = Pressostato	<i>Pressostat mecanique</i>	Mech. druckwaechter	<i>Mechanic pressure switch</i>	Presostato mecanico	<i>Interrup. Mec. Pressão</i>
<b>RC</b> = Resistenza caldaia	<i>Resistance chaudiere</i>	Kesselheizung	<i>Boiler Heating Resist.</i>	Resist. Caldera	<i>Resistência da caldeira</i>
<b>RP</b> = Relé pompa	<i>Relé pompe</i>	Relé pumpen	<i>Pump contactor</i>	Relé bomba	<i>Relé bomba</i>
<b>RR</b> = Relé macanza acqua	<i>Relé manque d'eau</i>	Relé Kein Wasser	<i>Water shortage relè</i>	Relé falte de agua	<i>Relé falta de água</i>
<b>RS</b> = Resistenza scaldatazze	<i>Resistance chauffe tasse</i>	Tassen warmerheizung	<i>Cups Heating Resistance</i>	Resist. Caliente tazas	<i>Resistência aquec. xícaras</i>
<b>SA</b> = Scheda autolivello	<i>Carte autoniveau</i>	Wasserstandkarte	<i>Autolevel board</i>	Ficha de autonivel	<i>Placa auto nível</i>
<b>SL</b> = Sonda Livello	<i>Sonde niveau</i>	Standfühler	<i>Level feeler</i>	Sonda nivel	<i>Sonda nível</i>
<b>SP</b> = Sensore di pressione	<i>Capteur de pression</i>	Drucksensor	<i>Autolevel board</i>	Detector de presión	<i>Sensor de pressão</i>
<b>ST</b> = Sonda temperatura	<i>Sonde Temperature</i>	Temperatur Sonde	<i>Temperature Probe</i>	Sonda de temp.	<i>Sonda temperatura</i>
<b>STS</b> = Sonda temp.TS/TSC	<i>Sonde Temperature TS/TSC</i>	Temperatur Sonde TS/TSC	<i>Temperature Probe TS/TSC</i>	Sonda de temp. TS/TSC	<i>Sonda temperatura TS/TSC</i>
<b>TA</b> = Tasto acqua	<i>Touche eau</i>	Wassertaste	<i>Key water</i>	Tecla agua	<i>Tecla água</i>
<b>TF</b> = Tastiera funzioni/servizi	<i>Clavier function/service</i>	Funktion/Dienst druck	<i>Function/service keyboard</i>	Botonera/Funciòn/ servicio	<i>Teclado funções/ serviços</i>
<b>TG</b> = Tastiera gruppo	<i>Clavier groupe</i>	Gruppedruckknoepfe	<i>Group Keyboard</i>	Botonera grupo	<i>Teclado grupo</i>
<b>TM</b> = Trasformatore	<i>transformateur</i>	Transformator	<i>Transformer</i>	Transformador	<i>Transformador</i>
<b>TP</b> = Tastiera programmazione	<i>Clavier de programmation</i>	Programmiertastatur	<i>Program Keyboard</i>	Botonera programación	<i>Teclado programação</i>
<b>TR(SR)</b> = Teleruttore	<i>Télérupteur</i>	Fernschalter	<i>Transformer</i>	Telerruptor	<i>Contador</i>
<b>TS</b> = Termostato di sicurezza	<i>Thermostat de sécurité</i>	Sicherheitsdruckwächter	<i>Safety thermostat</i>	Termóstato de seguridad	<i>Termostato de segurança</i>
<b>TTSC</b> = Tastiera TSC	<i>Clavier TSC</i>	Tastatur TSC	<i>TSC keyboard</i>	Botonera TSC	<i>Teclado TSC</i>
<b>VP</b> = Pompa a vibrazione	<i>Pompe à vibration</i>	Vibrationspumpe	<i>Vibration pump</i>	Bomba de vibraciòn	<i>Bomba com vibração</i>
<b>AR</b> = Arancio	<i>Orange</i>	Orange-farbig	<i>Orange</i>	Naranja	<i>Laranja</i>
<b>B</b> = Blu	<i>Bleu</i>	Blau	<i>Blue</i>	Azul	<i>Azul</i>
<b>BI</b> = Bianco	<i>Blanc</i>	Weiss	<i>White</i>	Blanco	<i>Branco</i>
<b>BIB</b> = Bianco-Blu	<i>Blanc-Bleu</i>	Weiss-Blau	<i>White-Blue</i>	Blanco-Azul	<i>Branco-Azul</i>
<b>BIN</b> = Bianco-Nero	<i>Blanc-Noir</i>	Weiss- Braun	<i>White-Black</i>	Blanco-Negro	<i>Branco-Preto</i>
<b>G</b> = Giallo	<i>Jaune</i>	Gelb	<i>Yellow</i>	Amarillo	<i>Amarelo</i>
<b>GV</b> = Giallo-Verde	<i>Jaune-vert</i>	Gelb-gruen	<i>Yellow-green</i>	Amarillo-verde	<i>Amarelo-Verde</i>
<b>GR</b> = Grigio	<i>Gris</i>	Grau	<i>Grey</i>	Gris	<i>Cinza</i>
<b>M</b> = Marrone	<i>Marron</i>	Braun	<i>Brown</i>	Marron	<i>Marrom</i>
<b>N</b> = Nero	<i>Noir</i>	Schwarz	<i>Black</i>	Negro	<i>Preto</i>
<b>R</b> = Rosso	<i>Rouge</i>	Rot	<i>Red</i>	Rojo	<i>Vermelho</i>
<b>RO</b> = Rosa	<i>Rose</i>	Rosa	<i>Rose</i>	Rosado	<i>Rosa</i>
<b>V</b> = Verde	<i>Vert</i>	Gruen	<i>Green</i>	Verde	<i>Verde</i>
<b>VI</b> = Viola	<i>Violette</i>	Violett	<i>Violet</i>	Morado	<i>Roxo</i>

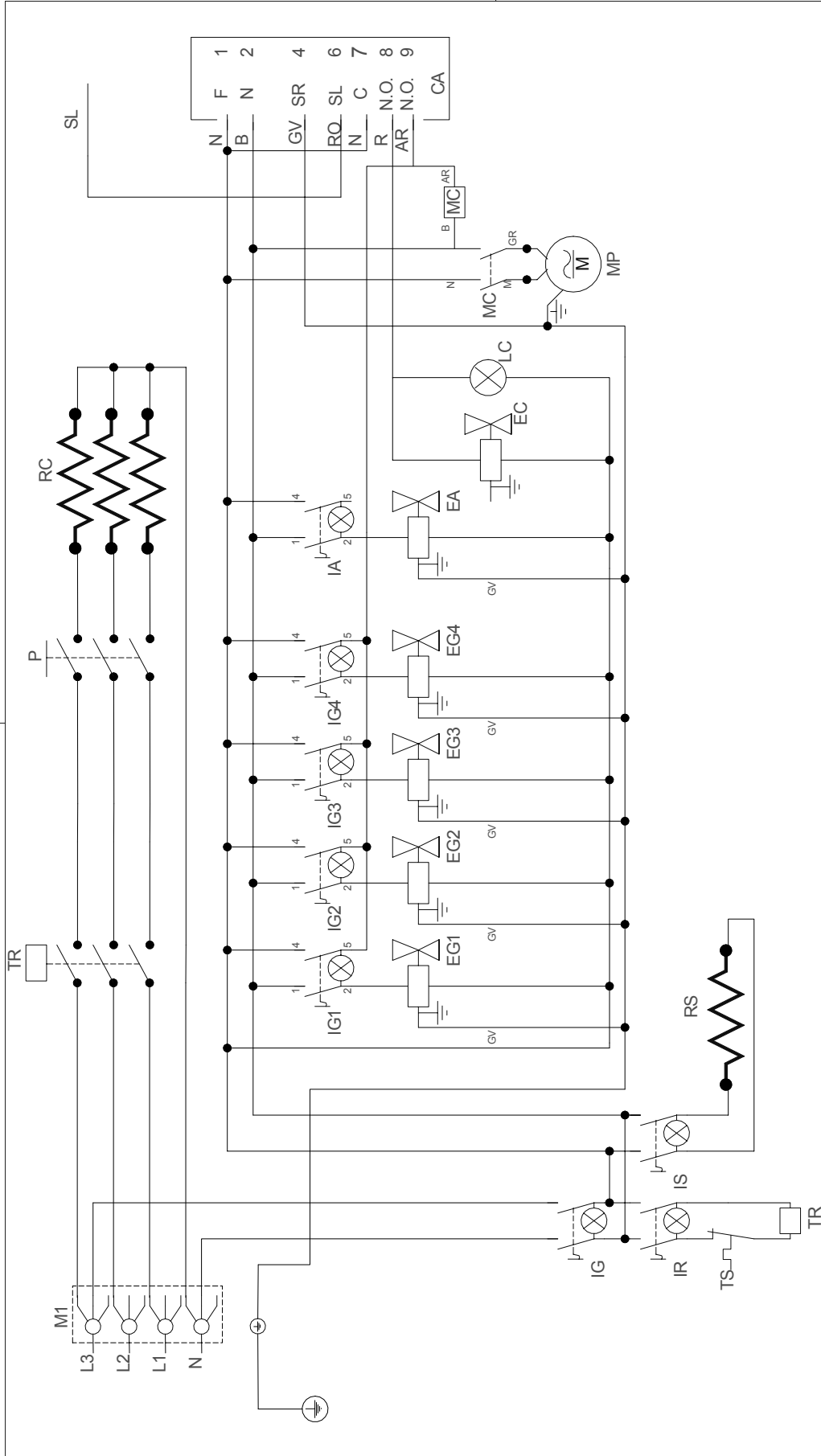

 <b>macchine per caffè</b> Viale della Repubblica 40 20010 Villastara di Parabiago-MI-Italia Tel +39 0331 408200 Fax +39 0331 551437 www.rancilio.com info@rancilio.it		Diffusione e riproduzione vietata a termini di legge senza nostra autorizzazione.
PROGETTO:	CLASSE 8	SCHEMA ELETRICO
DENOMINAZIONE: VERS. DE07 1 - 4 gr. 346 - 415 V/3N~ VERS. 2007		
CODICE:	SE_1338	Data: 07/11/07 Firma: U.T. Formato: A4



 <b>macchine per caffè</b> Viale della Repubblica 40 20010 Villafranca di Parabiago-MI-Italia Tel. +39 0331 409200 Fax +39 0331 551437 www.rancilio.com info@rancilio.it	PROGETTO:	CLASSE 8	SCHEMA ELETTRICO	Diffusione e riproduzione vietata ai termini di legge senza nostra autorizzazione.
	DENOMINAZIONE:	VERS. S 1+4 gr. 346 - 415 V/3N- VERS. 2007		Data: 07/11/07
	CODICE:	SE_1337		Firma: U.T.
				Formato: A4

REV.	DESCRIZIONE	DATA	FIRMA	N° CTI

**COLLEGAMENTO ELETTRICO  
BRANCHEMENT ELECTRIQUE  
STROMANSCHLUSS  
ELECTRONIC CONNECTION  
CONEXION ELECTRICA  
LIGAÇÃO ELÉTRICA**

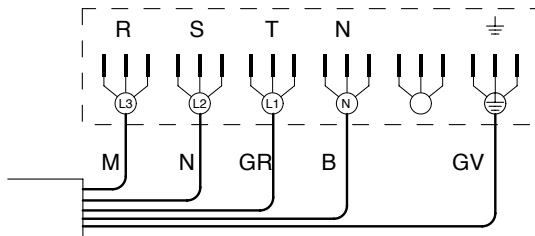

346 - 415 V / 3N~

COLLEGAMENTO TRIFASE A STELLA CON NEUTRO  
BRANCHEMENT TRIPHASE EN ETOILE AVEC NEUTRE  
DREIPHASIGER STERN ANSCHLUSS MIT MITTELEITER  
THREE-PHASE STAR CONNECTION WITH NEUTRAL  
CONEXION TRIFASICA A ESTRELLA CON NEUTRO  
LIGAÇÃO TRIFÁSICA EM FORMA DE ESTRELA, COM NEUTRA

1 / 2 GR. H07RN-F 5x2,5 mm<sup>2</sup>  
3 / 4 GR. H07RN-F 5x4 mm<sup>2</sup>

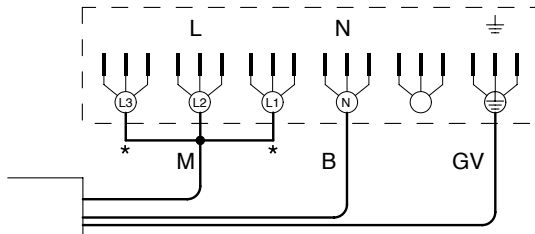

200 - 240 V~

COLLEGAMENTO MONOFASE  
BRANCHEMENT MONOPHASE  
EINPHASIGER ANSCHLUSS  
SINGLE-PHASE CONNECTION  
CONEXION MONOFASICA  
LIGAÇÃO MONOFÁSICA

1 / 2 GR. H07RN-F 3x2,5 mm<sup>2</sup>  
3 / 4 GR. H07RN-F 3x4 mm<sup>2</sup>

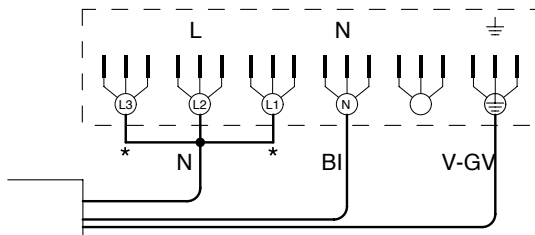

120V~ / 220V~ U.S.A.

COLLEGAMENTO MONOFASE  
BRANCHEMENT MONOPHASE  
EINPHASIGER ANSCHLUSS  
SINGLE-PHASE CONNECTION  
CONEXION MONOFASICA  
LIGAÇÃO MONOFÁSICA

1 / 2 GR. 120V~  
2/3/4 GR 220V~ SO, SJO, SJTO 3x10 AWG  
1 GR 220V~ SO, SJO, SJTO 3x12 AWG

★ PONTICELLI FORNITI IN DOTAZIONE  
JUMPERS ARE WITH THE SUPPLIED  
ZUSATZBRUCKEN SIND IN AUSSTATTUNG  
PONTETS INSERES DANS LA DOTATION  
PUENTES ESTAN INCLUIDOS EN EL MATERIAL DE DOTACION  
PONTINHAS FORNECIDAS

IL CONDUTTORE DI TERRA (GV) DEVE ESSERE PIU' LUNGO DI 9 cm RISPETTO AI RIMANENTI  
THE EARTH CONDUCTOR (GV) MUST BE LONGER THAN THE OTHERS OF 9 cm  
DER ERD STROMLEITER MUSS LAENGER ALS 9 cm IN BEZUG AUF DEN RESTLICHEN STROMLEITER SEIN  
LE CONDUCTEUR DE TERRE DOIT ETRE PLUS LONG DE 9 cm PAR RAPPORT A LES AUTRES  
LA LONGITUD DE LA TOMA DE TIERRA TIEN ESSER SUPERIOR A 9 cm RESPECTO AL RESTO  
O FIO TERRA (GV) DEVE SER 9 cm MAIS COMPRIDO DO QUE OS RESTANTES

M	=	MARRONE	MARRON	BRAUN	BROWN	MARRON	MARROM
N	=	NERO	NOIR	SCHWARZ	BLACK	NEGRO	PRETO
B	=	BLU	BLEU	BLAU	BLUE	AZUL	AZUL
BI	=	BIANCO	BLANC	WEISS	WHITE	BLANCO	BRANCO
V	=	VERDE	VERT	GRUEN	GREEN	VERDE	VERDE
GV	=	GIALLO-VERDE	JAUNE-VERT	GELB-GRUEN	YELLOW-GREEN	AMARILLO-VERDE	AMARELO-VERDE
BIN	=	BIANCO-NERO	BLANC-NOIR	WEISS-SCHWARZ	WHITE-BLACK	BLANCO-NEGRO	BRANCO-PRETO
BIB	=	BIANCO-BLU	BLANC-BLEU	WEISS-BLAU	WHITE-BLUE	BLANCO-AZUL	BRANCO-AZUL
VI	=	VIOLA	VIOLET	VIOLETT	VIOLETT	VIOLETA	ROXO
R	=	ROSSO	ROUGE	ROT	RED	ROJO	VERMELHO

**SCHEDA ELETTRONICA - CARTE ÉLECTRONIQUE - ELEKTRONIKKARTE -  
ELECTRIC BOARD - TARJETA ELECTRÓNICA - PLACA ELETRÔNICA  
mod. CLASSE 8 DE**

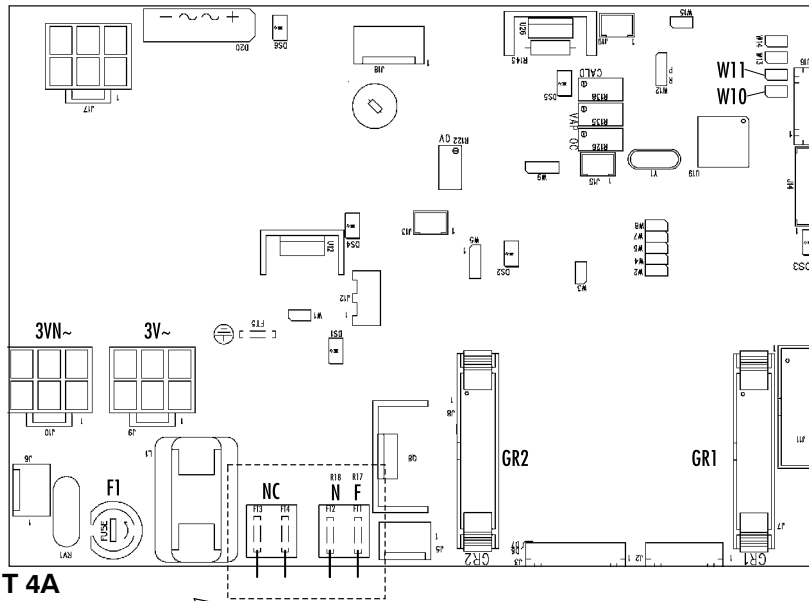

**F1 = T 4A**

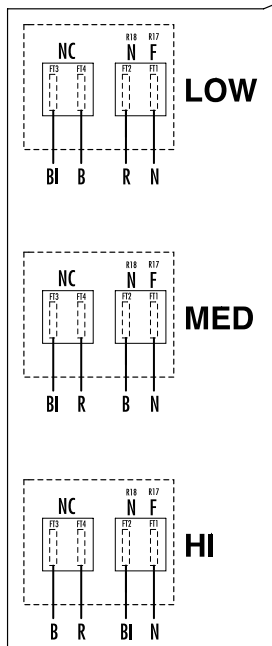

**COLLEGAMENTO TRASFORMATORE-BRANCHEMENT TRANSFORMATEUR  
TRANSFORMER CONNECTION-CONEXION TRANSFORMADOR  
STROMANCHHULUSS TRANSFOMATOR-LIGAÇÃO TRANSFORMADOR**

**ATTENZIONE**

La macchina è predisposta per un collegamento con la tensione nominale di 230V (MED).

Se la tensione di alimentazione è inferiore al 10% a tale valore, collegare come indicato su LOW.

Se la tensione di alimentazione è superiore al 10% a tale valore, collegare come indicato su HI.

**ATTENTION**

La machine est prédisposée pour un raccordement avec la tension nominale de 230V (MED).

Si la tension d'alimentation est inférieure de 10% par rapport à cette valeur, branchez comme indiqué sur LOW.

Si la tension d'alimentation est supérieure de 10% par rapport à cette valeur, branchez comme indiqué sur HI.

**ACHTUNG**

Die Maschine ist für eine Verbindung mit einer Nominalspannung von 230 V (MED) vorgesehen.

Ist die Versorgungsspannung um 10% niedriger, wie angegeben an LOW anschließen.

Ist die Versorgungsspannung um 10% höher, wie

angegeben an HI anschließen.

**WARNING**

The equipment has been designed for 230V (MED) rated power connection.

If power supply is lower than 10% of this value, connect as shown on LOW.

If power supply is higher than 10% of this value, connect as shown on HI.

**ATENCIÓN**

La máquina está prevista para ser conectada a una tensión nominal de 230V (MED).

Si la tensión de alimentación es inferior al 10% de dicho valor, conecten según lo indicado en LOW.

Si la tensión de alimentación es superior al 10% de dicho valor, conecten según lo indicado en HI.

**ATENÇÃO**

A máquina está predisposta para uma ligação com a tensão nominal de 230V (MED).

Se a tensão de alimentação é inferior a 10% a tal valor, ligar como indicado em LOW

Se a tensão de alimentação é superior a 10% a tal valor ligar como indicado em HI.

**W10=** Abilitazione programmazione dosi  
Dose setting mode  
Habilitation réglage des doses  
Dosierungs einsetzung betähigung  
Habilitación programación dosis  
Habilitação do programa das doses

**YES**

**NO**



**W11=** Potenza ridotta  
Reduction power  
Reduit puissance  
Verminderte leistung  
Potencia reducida  
Potência reduzida

**YES**

**NO**



## 200-240 3V~ mod. DE

### COLLEGAMENTO-RACCORDÉMENT-VERBINDUNG-CONNECTION-CONEXIÓN-LIGAÇÃO

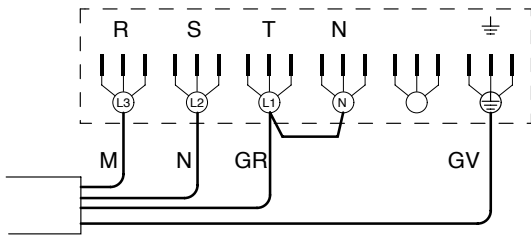

- 1) Collegare il cavo alimentazione come indicato in figura.
- 2) Spostare il collegamento delle resistenze dal connettore siglato 3VN~ in quello 3V~ sulla scheda di potenza
- 1) Raccorder le câble d'alimentation comme indiqué dans la figure.
- 2) Déplacer le raccordement des résistances du connecteur avec sigle 3VN~ dans celui 3V~ sur la carte de puissance

- 1) Das Versorgungskabel anbringen, wie es auf der Abbildung angegeben ist.
- 2) Die Verbindung der Widerstände von Verbinder 3VN~ auf Verbinder 3V~ auf der Leistungskarte umstecken.

- 1) Connect cable as shown in the picture.
- 2) On the power board, move resistance connection from connector marked 3VN~ to connector marked 3V~

- 1) Conectar el cable de alimentación como se ilustra en la figura.
- 2) Cambiar la conexión de las resistencias del conector con la sigla 3VN~ a 3V~ en la tarjeta de potencia.

- 1) Ligar o fio de alimentação como indicado na figura.
- 2) Transferir a ligação das resistências do conector siglado 3VN~ para àquele 3V~ na placa de potência.

## 200-240 3V~ mod. S

### COLLEGAMENTO-RACCORDÉMENT-VERBINDUNG-CONNECTION-CONEXIÓN-LIGAÇÃO

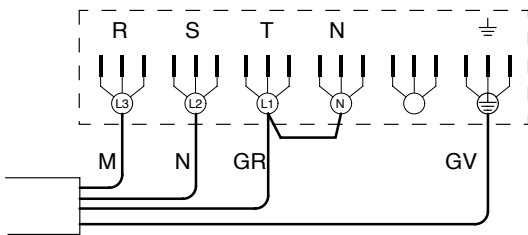

- 1) Collegare il cavo alimentazione come indicato in figura.
- 2) Scollegare i cavi azzurri (neutri) dalla resistenza elettrica ed isolarli.

- 1) Raccorder le câble d'alimentation comme indiqué dans la figure.
- 2) Débrancher les câbles bleus (neutres) de la résistance électrique et les isoler.
- 3) Raccorder la résistance électrique de la chaudière selon le schéma reporté ci-dessus.

- 1) Das Versorgungskabel anbringen, wie es auf der Abbildung angegeben ist.
- 2) Die blauen Kabel (Nullleiter) vom elektrischen Widerstand abtrennen und isolieren.
- 3) Den elektrischen Widerstand des Kessels anschließen, wie es weiter oben abgebildet ist.

- 1) Connect cable as shown in the picture.
- 2) Disconnect the light blue cables (neutral) from electric resistance and insulate them.
- 3) Connect boiler electric resistance according to the diagram below.

- 1) Conectar el cable de alimentación como se ilustra en la figura.
- 2) Desconectar los cables azules (neutros) de la resistencia eléctrica e aislarlos.
- 3) Conectar la resistencia eléctrica de la caldera según el esquema que se ilustra arriba.

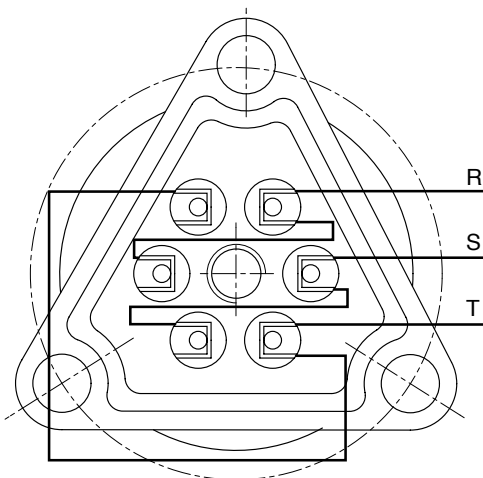



- 3) Collegare la resistenza elettrica della caldaia secondo lo schema sopra riportato.

- 1) Ligar o fio de alimentação como indicado na figura
- 2) Desligar os fios azuis (neutros) da resistência elétrica e isolá-los
- 3) Ligar a resistência elétrica da caldeira, segundo o esquema acima.

**SCHEMI IDRAULICI  
SCHÉMAS HYDRAULIQUES  
HYDRAULIKPLÄNE  
HYDRAULIC DIAGRAMS  
ESQUEMAS HIDRÁULICOS  
ESQUEMA HIDRÁULICO**

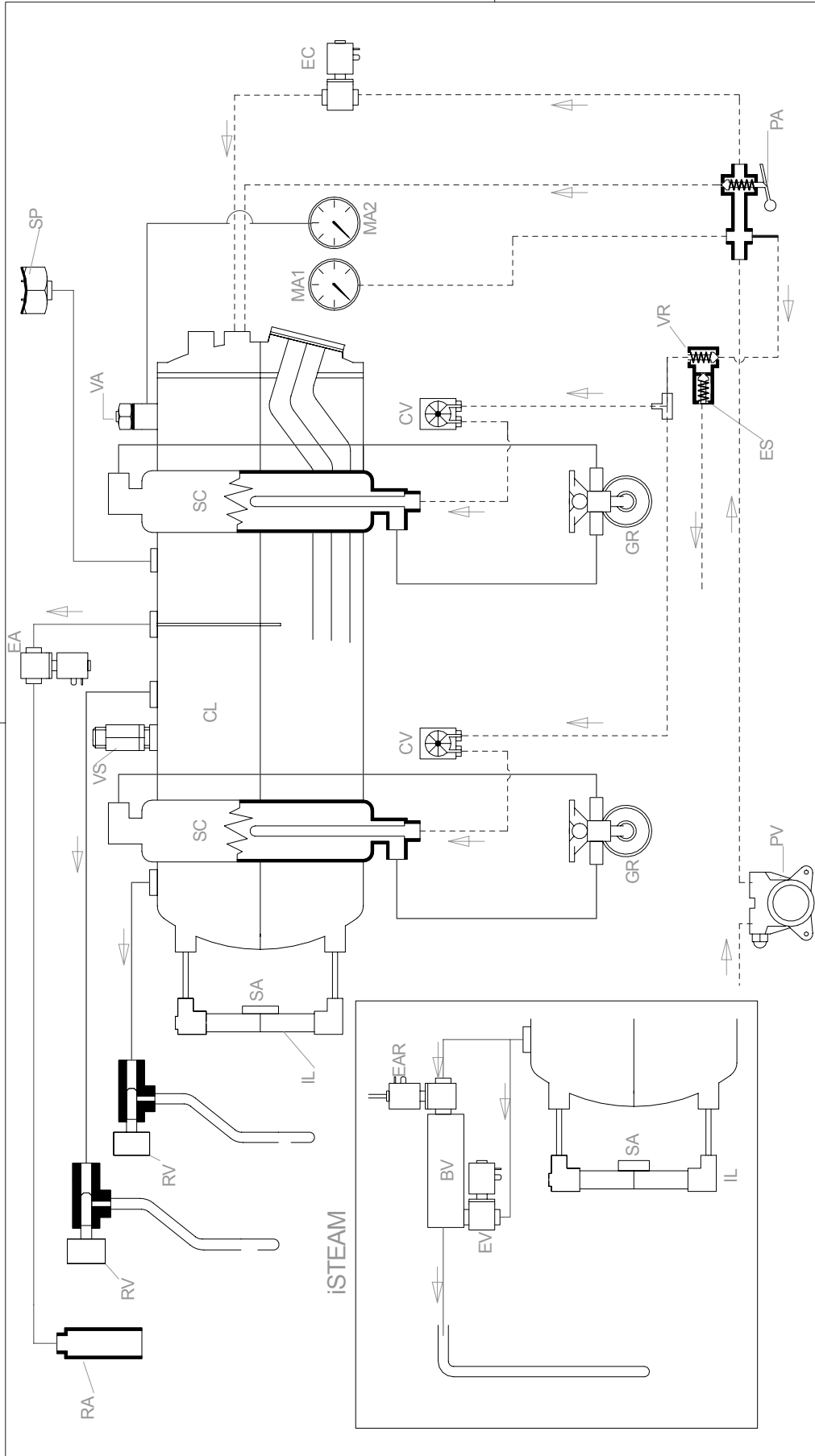
IT	FR	DE	EN	ES	PT
<b>CA</b> = Centralina autolivello	<i>Contrôle de niveau de l'eau</i>	Wasserniveauekontrolle	<i>Water level control</i>	Transd. autonivel	<i>Central auto nível</i>
<b>CL</b> = Caldaia	<i>Chaudière</i>	Kessel	Boiler	Caldera	<i>Caldeira</i>
<b>CV</b> = Contatore volumetrico	<i>Compteur volumétrique</i>	Volumenzaehler	<i>Flow Meter</i>	Contador volum.	<i>Contador volumétrico</i>
<b>EA</b> = Elettrovalvola acqua	<i>Electrovanne eau</i>	Wasserelektroventil	<i>Water electrovalve</i>	Electrovalvula agua	<i>Válvula Elétrica da água</i>
<b>EAR</b> = Elettrovalvola aria	<i>Electrovanne air</i>	Luftelektroventil	<i>Air electrovalve</i>	Electrovalvula aire	<i>Válvula Elétrica do ar</i>
<b>EC</b> = Elettrovalvola carico <i>abast.</i>	<i>Electr. de chargement</i>	Speisungselektroventil	<i>Feeding electrovalve</i>	Electrovalv. carga	<i>Válvula Elétrica</i>
<b>EE</b> = Miscelatore	<i>Mélangeur</i>	Mixer	<i>Mixer</i>	Mezclador	<i>Misturador</i>
<b>EG</b> = Elettrovalvola gruppo	<i>Electr. du groupe</i>	Gruppeeletroventil	<i>Group Electrovalve</i>	Electrovalvula grupo	<i>Válvula Elétrica grupo</i>
<b>ES</b> = Valvola di espansione	<i>valve d'expansion</i>	Expansionsventil	<i>expansion valve</i>	Válvula de expansión	<i>Válvula de expansão</i>
<b>EV</b> = Elettrovalvola vapore	<i>Electrovanne vapeur</i>	Dampfelektroventil	<i>Steam valve</i>	Electrovalvula vapor	<i>Válvula Elétrica vapor</i>
<b>GR</b> = Gruppo erogatore	<i>Groupe de distribution</i>	Brühgruppe	<i>Group</i>	Grupo erogador	<i>Grupo distribuidor</i>
<b>IL</b> = Indicatore livello	<i>Indicateur de niveau</i>	Pegelanzeiger	<i>Level indicator</i>	Indicador de nivel	<i>Indicador do nível</i>
<b>LC</b> = Lampada livello	<i>Lampe niveau</i>	Lampe für Wasserstand	<i>Level lamp</i>	Lámpara de nivel	<i>Lâmpada do nível</i>
<b>MA</b> = Manometro	<i>Manomètre</i>	Manometer	<i>Manometer</i>	Manómetro	<i>Manômetro</i>
<b>MA1</b> = Manometro Pompa	<i>Manomètre pompe</i>	Manometer Pumpe	<i>Manometer pump</i>	Manómetro bomba	<i>Manômetro Bomba</i>
<b>MA2</b> = Manometro Caldaia	<i>Manomètre chaudière</i>	Manometer Kessel	<i>Manometer boiler</i>	Manómetro caldera	<i>Manômetro Caldeira</i>
<b>P</b> = Pressostato	<i>Pressostat mecanique</i>	Mech. druckwaechter	<i>Mechanic pressure switch</i>	Presostato mecanico	<i>Interrup. Mec. Pressão</i>
<b>PV</b> = Pompa volumetrica	<i>pompe volumétrique</i>	Volumetrische Pumpe	<i>Volumetric pump</i>	Bomba volumétrica	<i>Bomba volumétrica</i>
<b>RA</b> = Rubinetto Acqua	<i>Robinet eau</i>	Wasserhahn	<i>Water tap</i>	Grifo de agua	<i>Torneira Água</i>
<b>RL</b> = Rubinetto Carico <i>Abastecimento</i>	<i>Robinet d'arrivée</i>	Auffüllhahn	<i>Inlet water tap</i>	Grifo de carga	<i>T o r n e i r a</i>
<b>RV</b> = Rubinetto Vapore	<i>Robinet vapeur</i>	Dampfhahn	<i>Steam tap</i>	Grifo de vapor	<i>Torneira Vapor</i>
<b>SA</b> = Scheda autolivello	<i>Fiche autoniveau</i>	Wasserstandkarte	<i>Autolevel board</i>	Ficha de autonivel	<i>Placa auto nível</i>
<b>SC</b> = Scambiatore di calore	<i>Échangeur de chaleur</i>	Wärmaustauscher	<i>Heat-exchanger</i>	Intercambiador de calor	<i>Intercambiador de calor</i>
<b>SL</b> = Sonda Livello	<i>Sonde niveau</i>	Standfühler	<i>Level feeler</i>	Sonda nivel	<i>Placa Nível</i>
<b>SP</b> = Sensore di pressione	<i>Capteur de pression</i>	Drucksensor	<i>Pressure sensor</i>	Detector de presión	<i>Sensor de pressão</i>
<b>ST</b> = Sonda temperatura	<i>Sonde Temperature</i>	Temperatur Sonde	<i>Temperature Probe</i>	Sonda de temp.	<i>Sonda temperatura</i>
<b>VA</b> = Valvola antidepressione	<i>Vanne antidépression</i>	Unterdruckventil	<i>Antivacuum valve</i>	Válvula antidepresión	<i>Válvula anti depressão</i>
<b>VP</b> = Pompa a vibrazione	<i>Pompe à vibration</i>	Vibrationspumpe	<i>Vibration pump</i>	Bomba de vibración	<i>Bomba com vibração</i>
<b>VR</b> = Valvola di ritegno	<i>Valve de retenue</i>	Rückschlagventil	<i>Check-valve</i>	Válvula de retención	<i>Válvula de retenção</i>
<b>VS</b> = Valvola di sicurezza	<i>Clapet de sûreté</i>	Sicherheitsventil	<i>Safety valve</i>	Válvula de seguridad	<i>Válvula de segurança</i>



 <b>macchine per caffè</b> Viale della Repubblica 40 20010 Villastanza di Parabiago-Mi-Italia Tel +39 0331 408200 Fax +39 0331 551437 www.rancilio.com info@rancilio.it	PROGETTO:	CLASSE 8	SCHEMA IDRAULICO	Diffusione e riproduzione vietata a termini di legge senza nostra autorizzazione.
	DENOMINAZIONE:	VERS. DE - iSTEAM 2 GR.		Data: 13/11/07
				Firma: U.T.
				Formato: A4



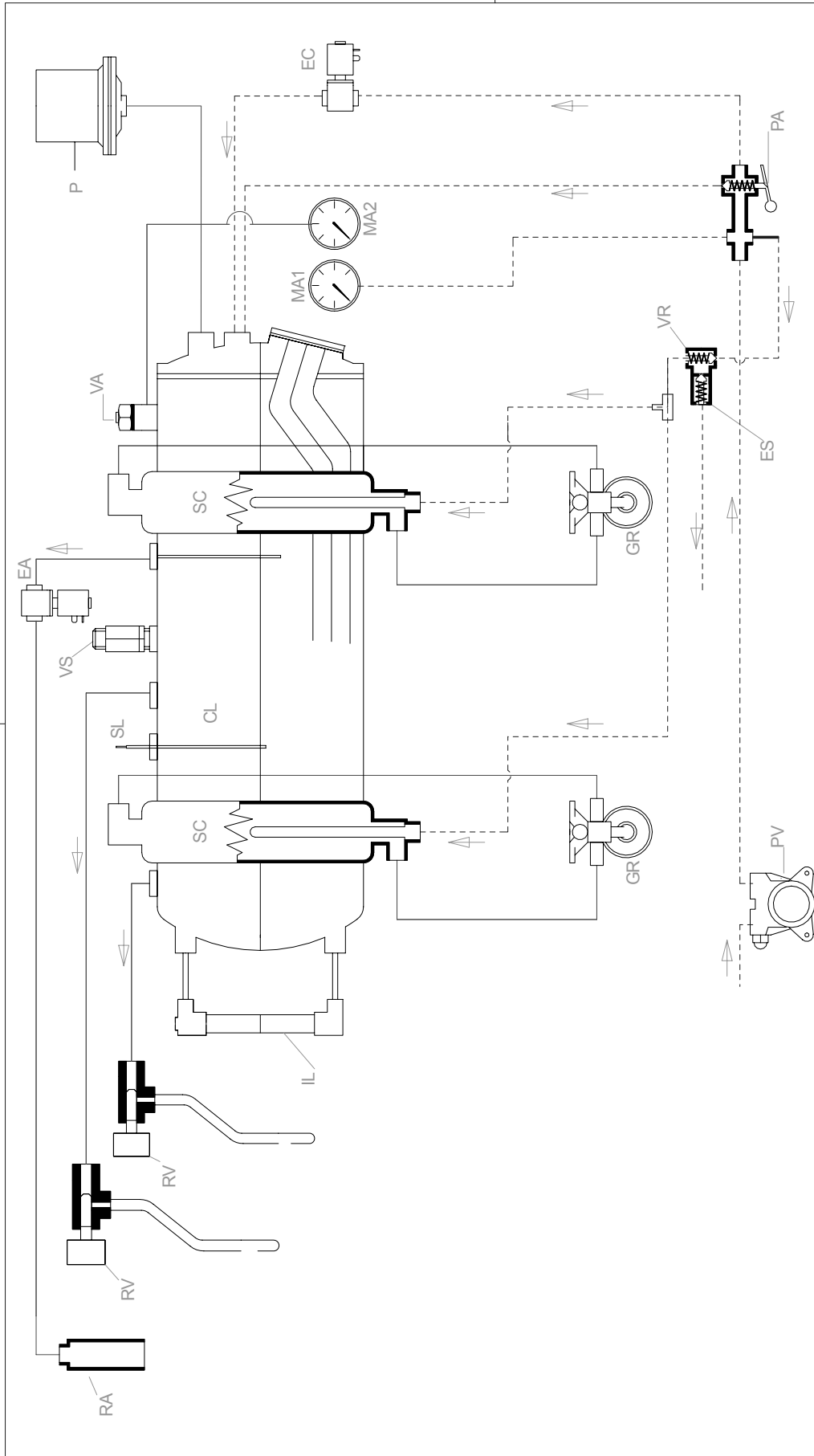

**RANCILIO**  
macchine per caffè

Viale della Repubblica 40  
20010 Villastanza di Ranciglio-M Italia  
Tel. +39 0331 408200  
Fax +39 0331 551437  
www.rancilio.com info@rancilio.it

PROGETTO:	CLASSE 8	SCHEMA IDRAULICO	Diffusione e riproduzione vietata a termini di legge senza nostra autorizzazione.
DENOMINAZIONE:			Data: 13/11/07
VERS. S 2 GR.			Firma: U.T.
CODICE:	SLC8_S	Formato:	A4





**IT** Proprietà riservata.

E' vietata la riproduzione totale o parziale del presente manuale senza l'autorizzazione scritta della RANCILIO S.P.A..

La ditta RANCILIO si riserva il diritto di apportare in ogni momento le modifiche che riterrà necessarie.

**FR** *Propriété réservée.*

*Il est interdit de reproduire totalement ou partiellement ce manuel sans l'autorisation écrite de la Société RANCILIO S.P.A..*

*La maison RANCILIO se réserve le droit d'apporter à tout moment les éventuelles modifications qu'elle jugera nécessaires.*

**DE** *Eigentumsrecht Vorbehalt.*

*Der teilweise oder gesamte Nachdruck dieses Handbuchs, ohne schriftliche Genehmigung der Fa. RANCILIO SPA ist verboten.*

*Die firma RANCILIO behält sich vor, eventuell notwendige Änderungen jederzeit durchzuführen.*

**EN** *Reserved property.*

*Partial or total reproduction of this manual is forbidden without written authorisation of RANCILIO S.P.A..*

*RANCILIO reserves the right to effectuate, in any given moment, any modifications which are considered necessary.*

**ES** *Propiedad reservada.*

*Prohibida la reproducción total o parcial del presente manual sin la autorización escrita de la RANCILIO S.P.A..*

*RANCILIO se reserva el derecho de aportar eventuales modificaciones que reputará necesarias en cualquier momento.*

**PT** *Propriedade reservada.*

*É proibida a reprodução total ou parcial do presente manual sem a autorização escrita da Rancilio S.P.A..*

*A fábrica RANCILIO reserva-se o direito de fazer, em qualquer momento, as modificações que julgar necessárias.*



*coffeeing the World*

---

RANCILIO MACCHINE PER CAFFÈ

STABILIMENTI E SEDE CENTRALE - 20010 VILLASTANZA DI PARABIAGO - MI (ITALY)

VIALE DELLA REPUBBLICA, 40 - TEL. 0331/408200 - TELEFAX 0331/551437