

# acaia Coffee Scale Operation Manual

Using Your acaia Coffee Scale

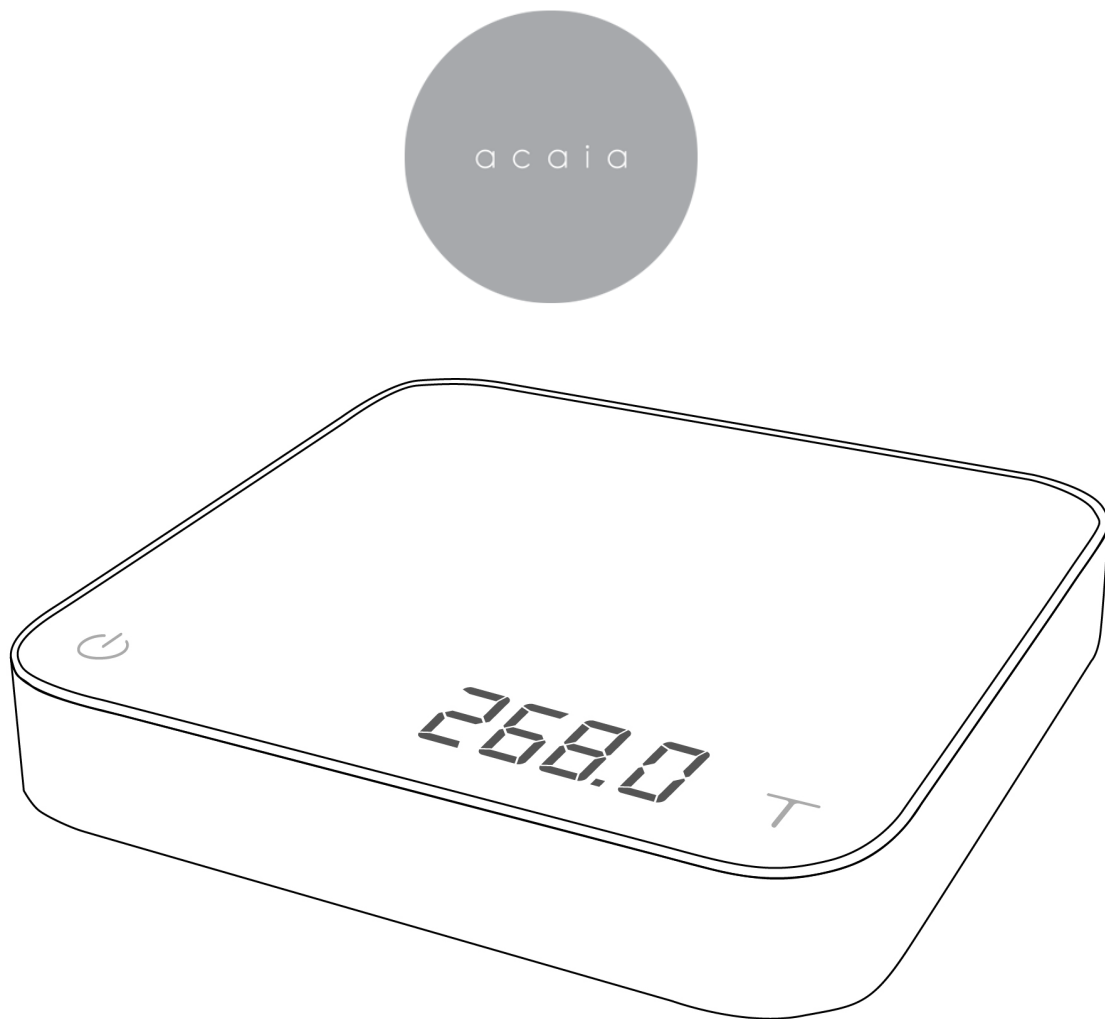

## Identification

The instructions in this operation manual apply to the acaia Coffee Scale. You have purchased a quality precision weighing scale that requires handling with care. Make sure to read through this operation manual prior to using the scale.

**CAUTION:**

- 1. Do not place any hot object directly on the weighing pan. Please use a heat resistant pad under hot objects.**
- 2. Any modification made without the consent of the manufacturer will result in the warranty being voided.**

# Contents

## **4 Chapter 1: Scale at a Glance**

- 4 Introduction
- 4 Specification
- 5 Scale overview
- 6 Accessories
- 6 Buttons
- 7 LED indicators
- 7 Battery charge

## **8 Chapter 2: Getting Started**

- 8 Preparation
- 9 Charging and Setup

## **10 Chapter 3: Basics**

- 10 An overview of operation structure
- 11 Basic operations
- 12 Weighing mode
- 12 Timer mode
- 13 Timer-weighing mode

## **14 Chapter 4: Configuration**

- 14 Setup mode
- 15 Setup mode settings
- 16 Auto Switch Off settings
- 16 Auto Zero settings
- 16 Zero Tracking
- 16 Key Sound Settings
- 17 Zero Range Settings
- 17 Weighing filter settings
- 17 Default weighing unit settings
- 18 Weighing resolution

## **19 Appendix A. Smart-Calibration**

- 19 Advanced operation structure
- 20 Calibration mode
- 20 Creep compensation mode

## **21 Appendix B. Error Codes**

- 21 Error code

## **22 Appendix C. Getting Firmware Version**

# Chapter 1: Scale at a Glance

## Introduction

Thank you for choosing one of our scales. The acaia Coffee Scale is designed and manufactured to the most rigorous standard to give you the best coffee brewing experience. Start by checking that your acaia Coffee Scale box contains all the parts listed below:

- |  |
|--|
| ● acaia Coffee Scale ● Micro USB cable |
|--|

Next, follow the instructions in the Preparation and Installation sections in the manual to get started.

To take an advantage of its many features, carefully read through the operation manual containing step-by-step procedures, examples, and other information.

**Warning: Incorrect handling of this product could possibly result in personal injury or physical damage.**

## Specifications

Aprox. weight	462g		
Capacity	2000g / 70.54oz		
Measuring Units	g , oz		
Weighing range 1	Maximum capacity	1000.0g	35.280oz
	Minimum capacity	1.0g	0.035oz
	Division	0.1g	0.005oz
Weighing range 2	Maximum capacity	2000.0g	70.540oz
	Minimum capacity	1000.0g	35.280oz
	Division	0.5g	0.020oz
Indication limit	2060.0g / 72.660oz		
Unit dimensions	(L x W x H) 160x160x30mm		
Electrical Requirements	5V/500mA		
Power and Battery	Lithium-ion rechargeable 3.7V 1100mA		
Display	6 digit Blue-White LED		
Buttons	Touch sensitive		
Bottom	anti-slip, rubber, flat surface.		
Connectivity	Bluetooth 4.0		
Linearity	+/- 0.2g		
Work time (battery life)	Up to 25 hours		

## Scale Overview

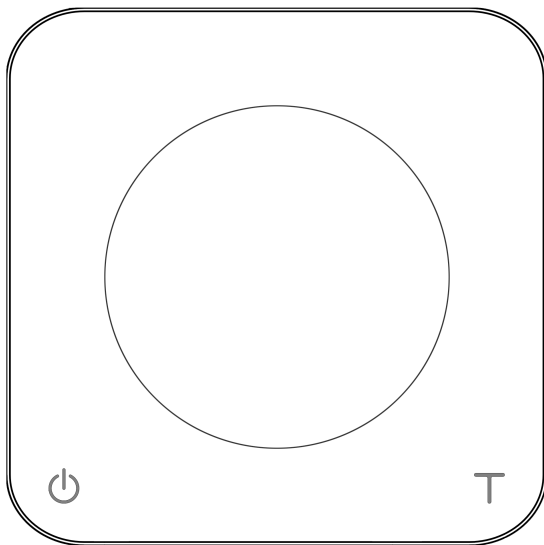
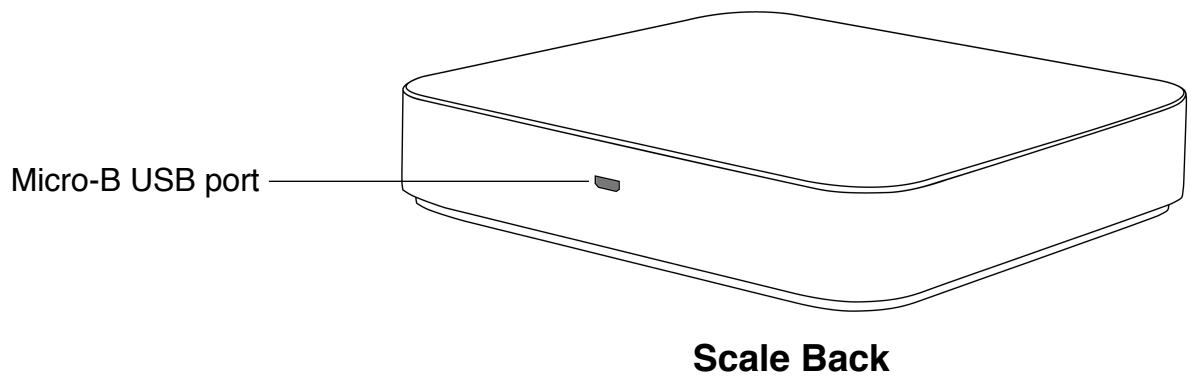
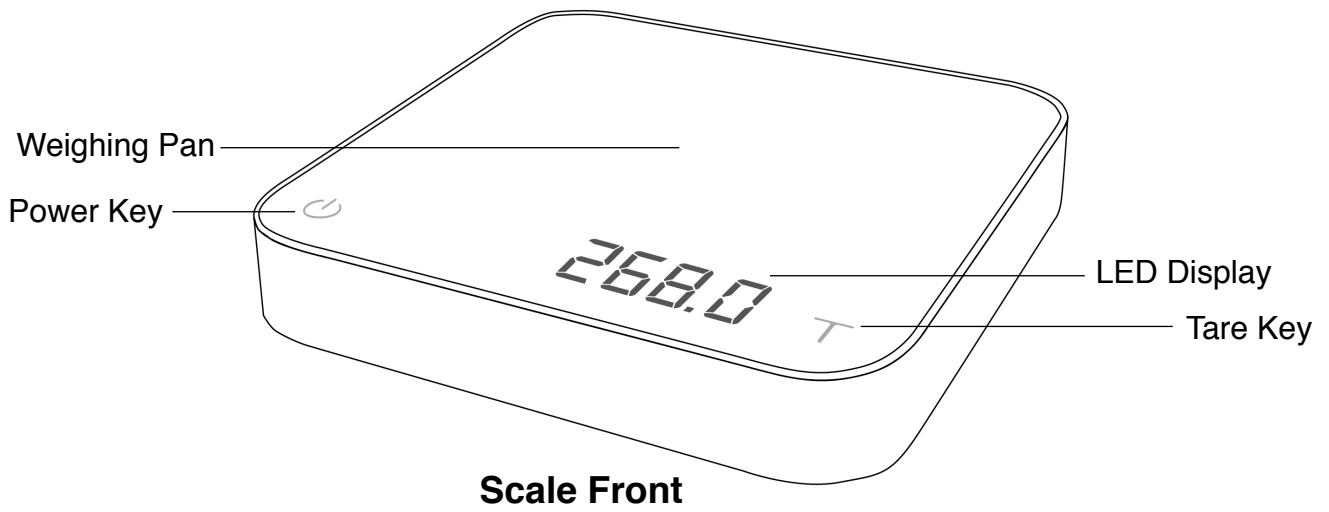

\*Note: For the best performance, place the weight in center of weighing platform.

## Accessories

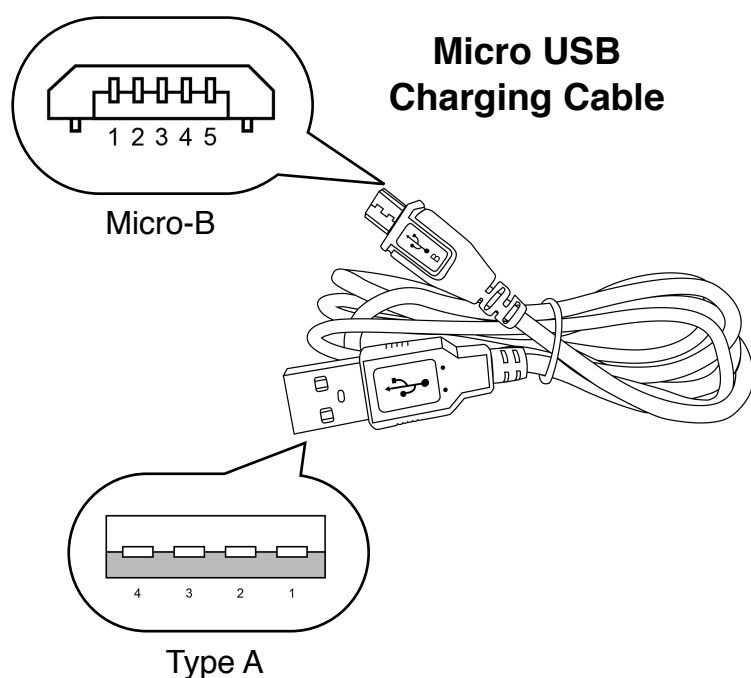

## Heat Resistant Pad

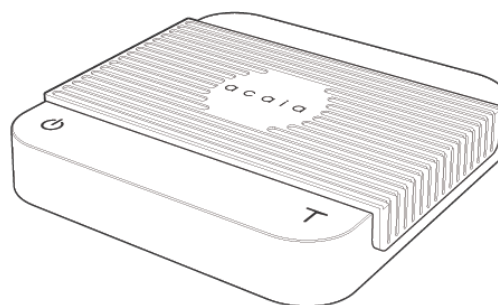

## Buttons

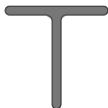
	Function	Example
<b>Power Button</b> 	Turn on	Press and hold for 0.5 seconds to turn on the scale.
	Turn off	Press and hold for over 3 seconds to turn off the scale.
	Switch mode	While the scale is turned on, press and hold for 1 second to switch mode: Weighing Mode / Timer Mode / Timer-Weighing Mode.
	Start / pause timer	While in Timer Mode, press to start or pause timer.
	Back	While in Setup Mode, press to go back to Weighing Mode from menu tree.
<b>Tare button</b> 	Tare	While in Weighing Mode and Timer-Weighing Mode, press to make tare operation.
	Switch weighing unit	While in Weighing Mode, press and hold to switch weighing unit.
	Reset timer	While in Timer Mode and Timer-Weighing Mode, press and hold to reset timer.
	Switch option	While in Setup Mode, press to switch options.
	Confirm	While in Setup Mode, press and hold for 1 second to confirm the option selected.
Enter calibration modes	<ol style="list-style-type: none"> <li>1. While in Weighing Mode, continuously press multiple times to enter Calibration Mode.</li> <li>2. While in Calibration Mode, continuously press multiple times to enter Creep Compensation Mode.</li> </ol>	

\* Please see **Chapter 3: Basics** for more details.

## LED Indicators

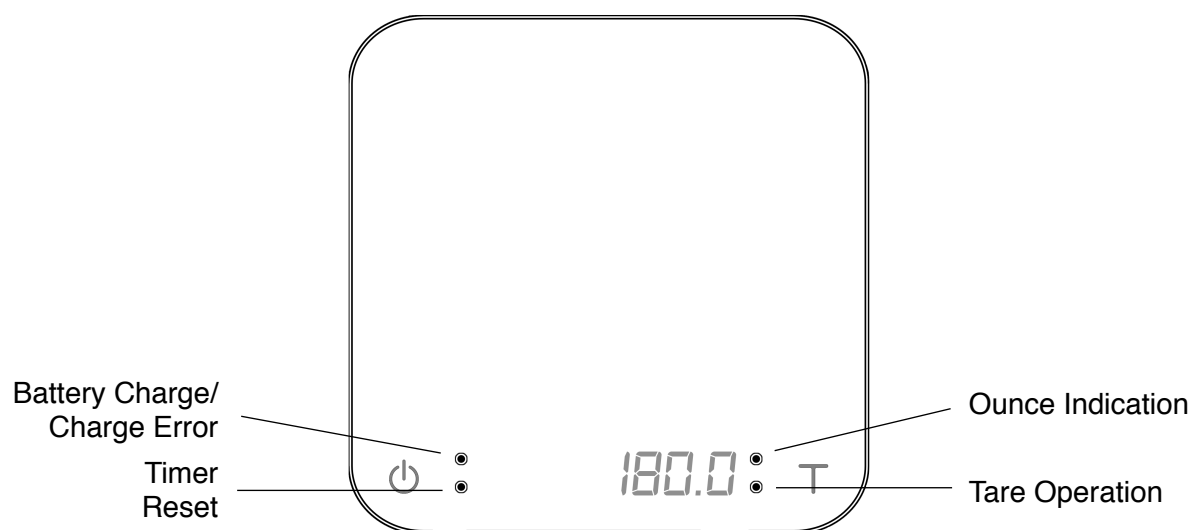

### Battery Charge / Charge Error

The upper left LED indicator lights orange when the battery is charging and turns off when the battery is fully charged. The indicator flashes when there is a problem with the USB cable.

### Timer Reset

The timer displays from 0 to 59 seconds in cycle and will reset when reaching 60 seconds. The lower left LED indicator lights orange when the timer resets.

### Tare Operation

The lower right LED flashes green when the **T** button is pressed.

### Ounce Indication

The upper right LED lights green when the weighing unit is set to ounces.

## Battery Charge

- You can charge the battery by plugging the USB cable to any power supply listed below:
  - A computer USB port
  - A cell phone charger with a micro USB connector
  - The supplied AC adapter
  - An automotive cell phone charger with a USB port or a Micro USB cable
- It takes 1-2 hours to fully charge the battery. You can charge the battery more frequently so that it will never hit empty.
- A fully charged battery will last for about 25 hours of use.
- Battery percentage can be viewed via acaia APP.
- It is not recommended to let the battery run out completely before charge.

# Chapter 2: Getting Started

## Preparation



- This scale is intended for indoor use.



- Select a work place that is stable, vibration-free and, if possible, a horizontal location for the weighing platform.



- Do not locate the scale near any equipment/instrument which contains magnets.

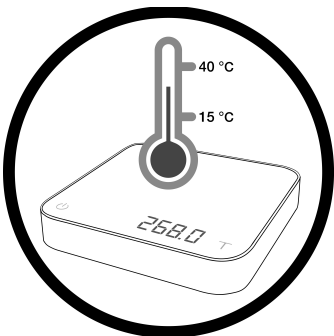

- Avoid places where room temperatures are unstable. Room temperature above 40°C or below 15°C may result in weighing inaccuracy.



## Charging and Setup

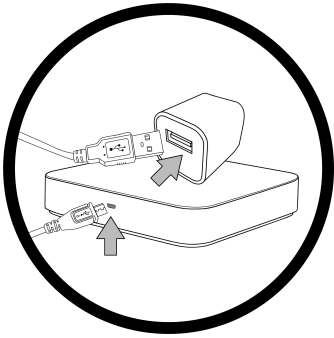

- To use AC adapter instead of the built-in battery, plug the USB cable into the Micro-B USB port located on the back panel of the scale.



- Press  button for 0.5 seconds to turn on the scale.



- Please make sure to use a heat resistant pad under hot objects.

# Chapter 3: Basics



## An Overview of Operation Structure

\*Note :The dashed line applies to firmware 1.72, indicating that the default Timer Mode is turn off.

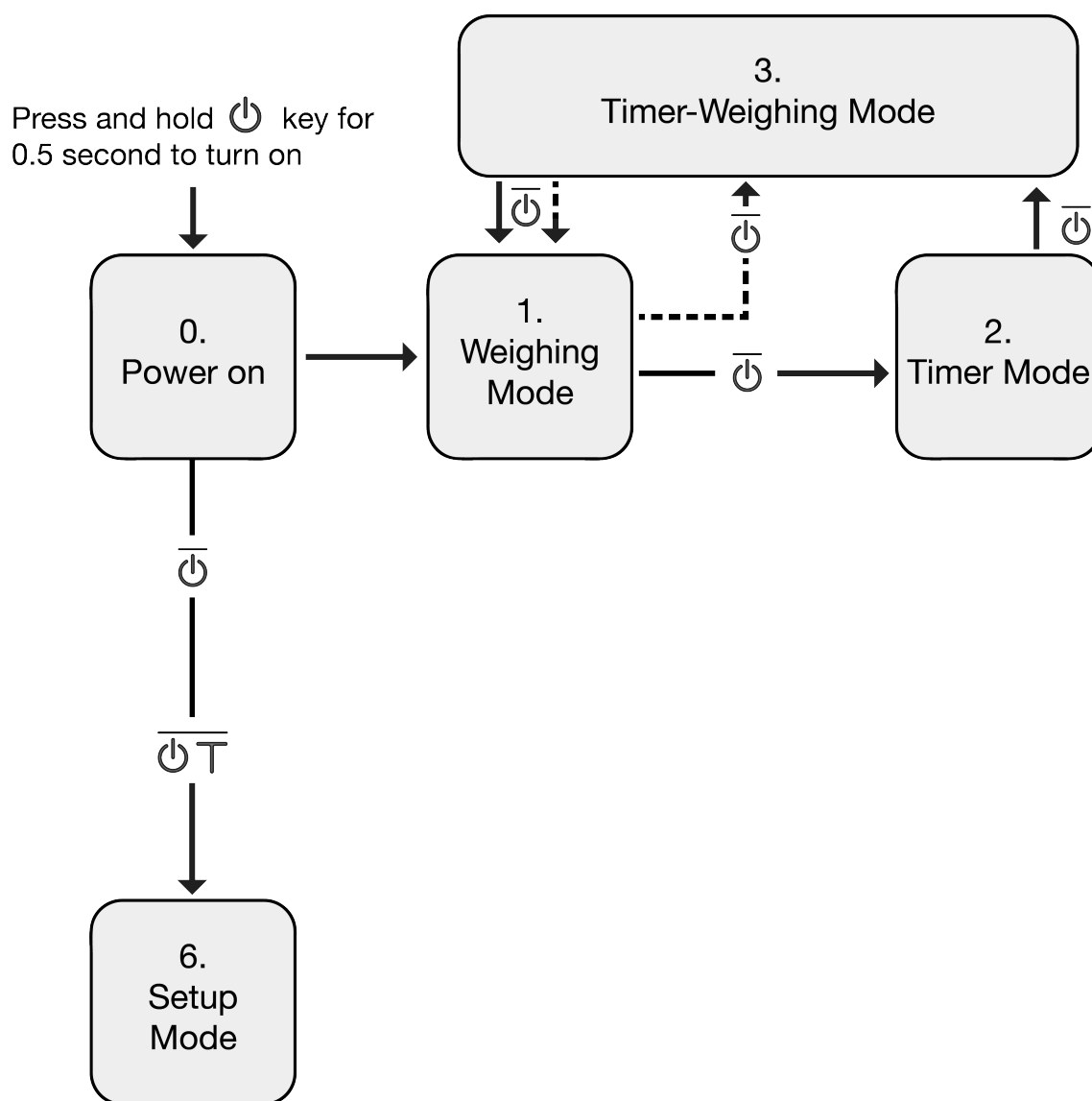
\*To obtain the firmware version, please see **Appendix C. Getting Firmware Version for more details.**



**Key operations:**

-  Press and hold P key for about 1 second.
-  Press and hold both P key and T key for about 1 second.

## Basic Operations

### Turn On

Press and hold  button for 0.5 seconds to turn on the scale.

### Turn Off

Press and hold  button for 3 seconds to turn off the scale.

### Switch Modes

Press and hold  button for 1 second each time to toggle through different modes.

Note :The dashed line applies to firmware 1.72, the default Timer Mode is turn off.

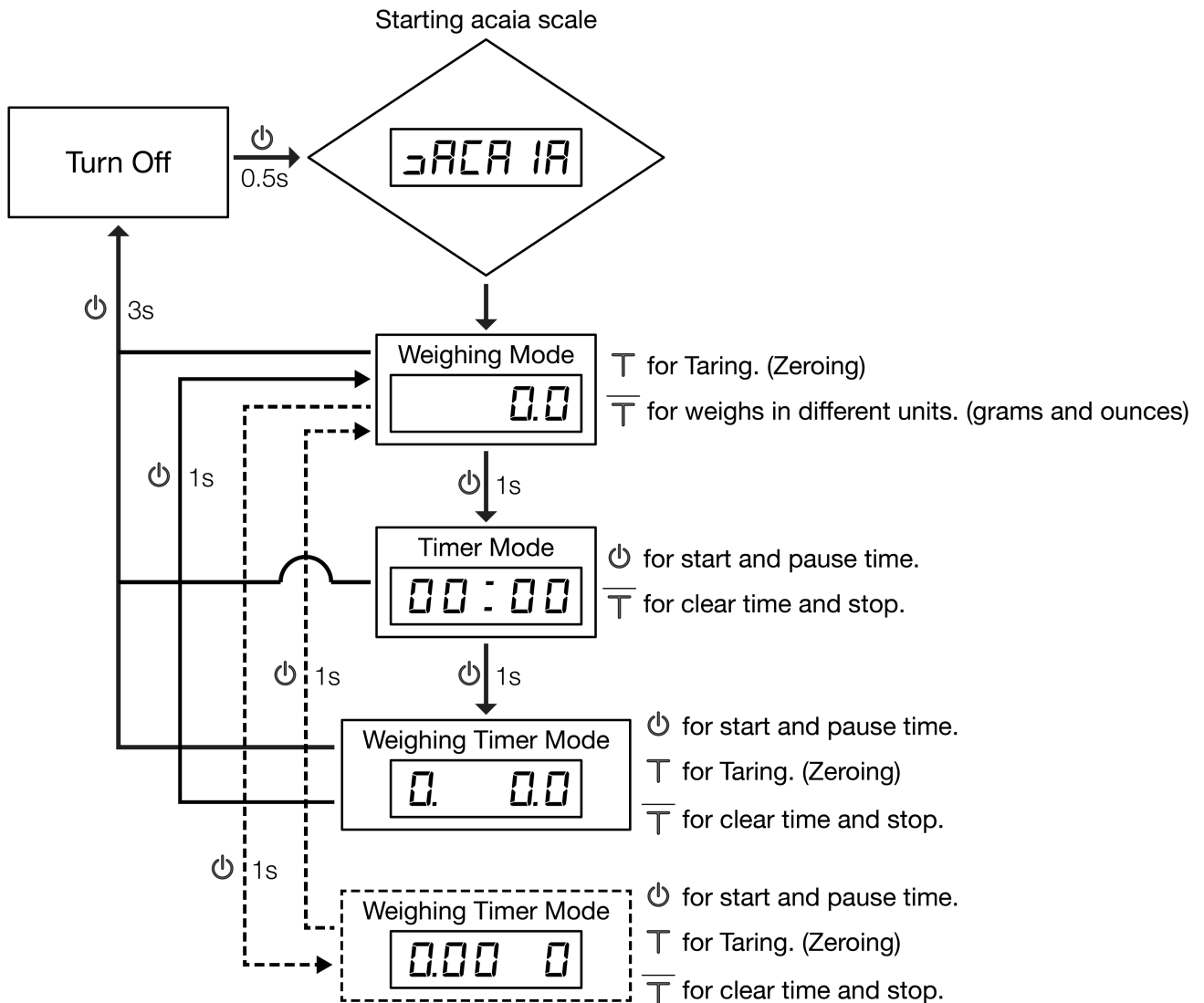

#### Key operations:

-  Click **T** key.
-  Press and hold **T** key for about 1 second.
-  Click **power** key.

## Weighing Mode

### Display

- There are two different weighing units in Weighing Mode: grams and ounces.
- The readability is 0.1g for grams and 0.005oz for ounces.
- The LED display shows [ 0.0]. when the weighing unit is in gram.
- The LED display shows [ 0.000]. when the weighing unit is in ounce.

### Operation



1. Press **T** button for tare (zero) operation.
2. Press and hold **T** button for 1 second to switch the weighing unit in between gram and ounce.
3. Press and hold  button for 1 second to switch to Timer Mode.

## Timer Mode

### Display

- For firmware 1.2 to 1.62, The LED display shows [ 00:00] in Timer Mode.
- In firmware 1.72, the Timer Mode is turn off. If you want to use it, please see **Chapter 4: Default Timer Setting** for more details.

### Operation

1. Press  button to start or pause the timer.
2. Press and hold **T** button for 1 second to stop and reset the timer.
3. Press and hold  button for 1 second to switch to Timer-Weighing Mode.

### Note

1. The maximum time that can be displayed is 999 minutes and 59 seconds.
2. The timer stops when the maximum time is reached.

## Timer-Weighing Mode



### Display(For firmware 1.2 to 1.62)

1. The LED display shows [ 0. 0.0] in Timer-Weighing Mode with timer on the left and the weight value on the right.
2. The timer displays from 0 to 59 seconds in cycle and will reset when reaching 60 seconds. When it resets, the LED indicator on the left lights on in orange to let you know that more than 1 minute has passed.
3. The weight division decreases when the weight is over 199.9. The LED display shows up to [ 1999 ] in maximum.

### Display(For firmware 1.72 default setting)

1. The LED display shows [ 0.00. 0] for grams or [ 0.000.0.000] for ounces in Timer-Weighing Mode with timer on the left and weight value on the right.
2. The timer displays from [0.00] to [9.59] and then the timer will stop.
3. When the weight is more than 1000 g, the LED indicator on the left lights on in orange to let you know the weight is more than 1000 g.
4. The weight division decreases when the weight is over 99.9 for grams or 70.5 for ounces. The LED display shows up to [ 999 ] or [ 70.5] in maximum.
5. If the weight values is below zero, then the LED will show up [ .- ], and the weight will keep flashing until it becomes positive.







## Operation

1. Press  button to start or pause the timer.
2. Press **T** button for tare (zero) operation.
3. Press and hold **T** button for 1 second to stop and reset the timer.
4. Press and hold  button for 1 second to switch to Weighing Mode.



# Chapter 4: Configuration

## Setup Mode

### Steps to enter Setup Mode

1. Press and hold  button while turning ON the scale. When the LED display shows [ *ON CAL R* ] and then [ *SET* ], press and hold  button for another 1 second without releasing  button. Release both  and  buttons when the display shows [ *F.0000* ], with the very left 0 flashing.
2. Press and hold  button for 1 second to move the flashing digit to the right. Repeat this step for 4 times to enter the first setting in Setup Mode: the LED display shows [ *SLEEP* ].

### Key Operations in Setup Mode

1. Press  button to toggle through setting menu or the options under each setting.
2. Press and hold  button to enter each setting or to confirm the selected option.
3. Press  button to return to setting menu without saving or to return to Weighing Mode from setting menu.

# Setup Mode Settings

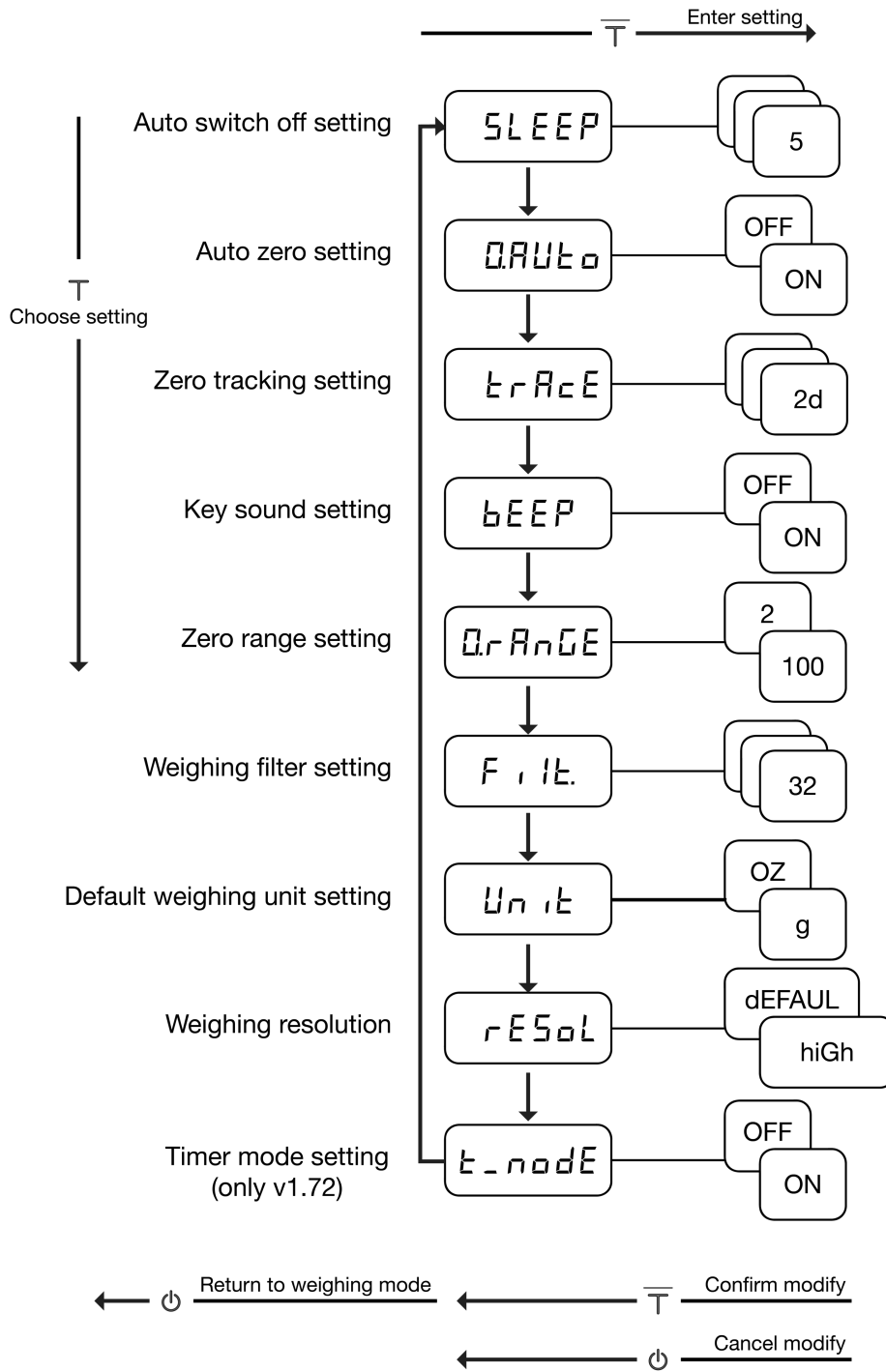

## Key operations:

- T Click T key.
- T Press and hold T key for about 1 second.
- Power key icon Click Power key icon key.

## Auto Switch Off Settings [ *SLEEP* ]

Auto Sleep Settings can also be configured in the acaia APP.

1. The number indicates the amount of time before the scale enters sleeping mode. For example, when 10 is selected, the scale enters sleeping mode after 10 minutes of idling.
2. Press **T** button to toggle through the options.
3. Press and hold **T** button for 2 seconds until the next setting, [ *0.AUTO* ], is shown on LED to confirm the selected option.

## Auto Zero Settings [ *0.AUTO* ]

1. When Auto Zero setting is off or disabled, the initial weight on weighing pan must be less than 50% of capacity, i.e., less than 1kg for acaia Coffee Scale before the scale is turned on ; otherwise, an error [ *Er.303* ] occurs. When the error occurs, the scale would not work until the initial weight on weighing pan is cleared.
2. When Auto Zero setting is on or enabled, the scale displays the initial weight directly regardless whether the weight is over 50% of capacity.

## Zero Tracking [ *TrAcE* ]

Zero Tracking is a function for maintaining the zero indication within certain limits automatically.

1. OFF: It is not recommended to turn off the Zero Tracking because the zero indication would drift easily as room temperature changes.
2. 0.5d~3d: For example, since each division is 0.1g, 3d = 0.3g. When Zero Tracking is set to be 3d, any initial weight between +/- 0.3g on the weighing pan would be zeroed out.
3. 2d is recommended in general for acaia Coffee Scale.

## Key Sound Settings [ *bEEP* ]

Key Sound Settings can also be configured in the acaia APP.

- Set the Key Sound function off to turn off the beeping sound or on to turn on the beeping sound.



## Zero Range Setting [ *0.RANGE* ]

Zero Range setting determines the range for which **T** button executes zero operation instead of tare operation.

1. When Zero Range is set to 2, the range for zero-setting will be 2% of the capacity, i.e., +/- 40g for acaia Coffee Scale. By pressing **T** button, any weight within +/- 40g is zeroed out by zero operation while any weight lays outside the range is tared out by tare operation.
2. If Zero Range is set to 100, the range for zero-setting will be 100% of the capacity, i.e., +/- 2kg for acaia Coffee Scale. Therefore, instead of tare operation, zero operation would be executed in this setting whenever **T** button is pressed.

Notice: The difference between zero operation and tare operation is that zero operation would simply ignore the weight and display as 0 while tare operation would deduct the weight from weighing result. However, zero operation does not increase the scale capacity.

## Weighing filter setting [ *FILT.* ]

1. The number shown on LCD display indicates the current filter parameter which determines the speed for load receptor to response to weight and to determine the weighing value. The larger the number, the more stable but slower the weighing result will be.
2. Press **T** button to change the parameter.
3. Press and hold **T** button for 1 second until the next setting, [ *UNIT* ] is shown on the LED to confirm the selected parameter.

## Default Weighing Unit [ *UNIT* ]

1. The Default Weighing Unit is set to be gram if [ *g* ] is selected and ounce if [ *oz* ] is selected.
2. Press **T** button to switch the Default Weighing Unit between gram and ounce.
3. Press and hold **T** button for 1 second until [ *RESET* ] is shown on LED to confirm the selected option.

## **Weighing resolution [ *rESOL* ]**

1. The default Weighing Resolution is set to [ *DEFAULT* ]: the division is 0.1g under weight of 1000g and 0.5g from 1000g to 2000g.
2. Press **T** button to switch the weighing resolution between [ *DEFAULT* ] and [ *High* ].
3. When the Weighing Resolution is set to high, division will be 0.1g throughout the entire time from 0g to 2000g.
4. Press and hold **T** button for 1 second until [ *SLEEP* ] is shown on LED to confirm the selected option.

## **Timer mode setting [ *t\_mode* ]**

In firmware 1.72, the default Timer mode is set to OFF.

1. OFF: The Timer mode is disabled, the scale will display two modes : Weighing Mode and Timer-Weighing Mode.
2. ON: The Timer mode is turn on, the scale will display three modes: Weighing Mode, Timer Mode and Timer-Weighing Mode.

# Appendix A. Smart-Calibration

If you decide to calibrate your scale, it will only be as good as the accuracy of the calibration weights you use. It is recommended to use standard weights of 500g or 1000g.

\*Note : We recommend standard weights with class F<sub>1</sub> or F<sub>2</sub>.

## Advanced operation structure

\*Note :The dashed line is for firmware 1.72, the default Timer Mode is turn off.

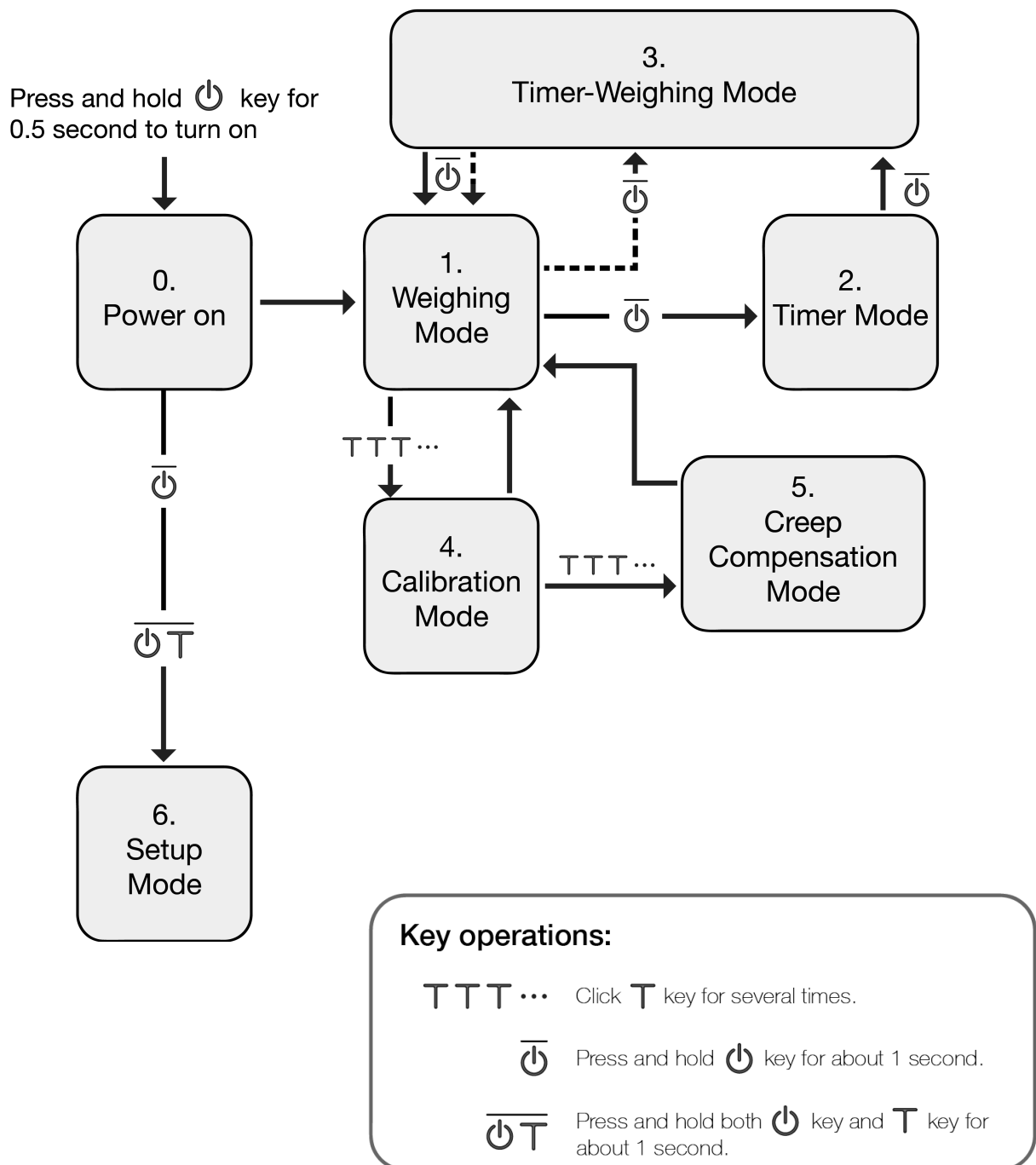

## Calibration Mode

1. While the scale is in Weighing Mode and the weighing unit is in gram, press **T** button quickly multiple times until LED display shows [ *CAL* ] and then [ *500* ].
2. Here is an example of using 500g for calibration. Place a 500g standard weight on scale and wait for the scale to execute calibration procedure.
3. The LED display shows [ *-End-* ] when the calibration procedure is completed. You may unload the calibration weight when completed.



\* Note: For calibration, we recommend 500g or 1000g standard weight. If you always use the chemex to brew your coffee, please use 1000g standard weight. Otherwise, use 500g standard weight.

## Creep Compensation Mode

1. While the scale is in Calibration Mode and the LED display shows [ *CAL* ] and then [ *500* ], press **T** button quickly multiple times until the LED display shows [ *CAL2* ] and then [ *2000* ].
2. Place a 2000g calibration weight on scale and wait for the scale to execute creep compensation procedure.
3. The LED display shows [ *-End-* ] when the creep compensation procedure is completed. You may unload the calibration weight when completed.



# Appendix B. Error Codes

## Error Code

Error Code	Description
100	Code error
101	EEPROM error
102	AD read error
	Over load: the weight is over the maximum capacity.
	Under load: the weight is under the minimum capacity.
303	Unable to make zero point, for the initial weight exceeds the limit (50% of capacity).
304	Weight calibration error.
904	Password error (the default password is 0000)

# Appendix C. Getting Firmware Version

## Operations

1. Press and hold  while turning on the scale. When the LED display shows *nAChA A* and then *SEt*, release  .
2. For version 1.2(some of early birds), the LED will display *rEu- 1.2*.  
For version 1.3, the LED will display *rEu- 1.3*.  
For version 1.4, the LED will display *rEu- 1.4*.  
For version 1.5, the LED will display *rEu- 1.5*.  
For version 1.62, the LED will display *UP- 1.0* then *rEu- 1.62*.  
For version 1.72, the LED will display *- 1.72 -*.

## Copyright

The operation manual is protected by copyright. All rights reserved. No part of the operation manual may be reproduced, processed, duplicated or published in any form by photocopying, microfilming, reprinting or any other method, in particular electronic means, without the written agreement of acaia.

© acaia, Cupertino, CA, 2014.